

WAREHAM TOWN CLERK  
2024 FEB 28 AM 9:47



**TOWN OF WAREHAM**

**SUBDIVISION RULES & REGULATIONS**

**ADOPTED FEBRUARY 26, 2024**

## **Section I – General**

### **A. Authority**

Under Article 34 of the Annual Town Meeting held on March 5, 1951, it was voted to establish a Planning Board consisting of five (5) members under the provisions of Massachusetts General Laws, Chapter 41, §81A to 81Y inclusive, with all Powers and Duties therein.

Under the authority vested in the Planning Board of the Town of Wareham by Massachusetts General Laws, Chapter 41, §81Q, said Board hereby adopts these Rules and Regulations Governing the Subdivision of Land in the Town of Wareham. Such Rules and Regulations shall be effective, as amended on and after January 1, 2024.

No plan will be accepted for recording by either the Plymouth County Registry of Deeds or the Land Court unless the plan has first either been approved as a subdivision or endorsed that it does not require such approval by the Planning Board or conforms to the provisions of MGL Chapter 41, Section 81X.

No person shall make such a subdivision within the meaning of the Subdivision Control Law of any land within the Town of Wareham or proceed with the improvement or sale of lots in a subdivision or the construction of ways or the installation of municipal services therein, unless and until a Definitive Plan of such subdivision has been submitted to and approved by the Wareham Planning Board as hereinafter provided.

### **B. Compliance**

Subdivision plans shall conform to the rules and accepted principles of good planning and appropriate engineering. The Planning Board assumes that information submitted to it is true and correct unless there appears to be evidence to the contrary. The acquisition of necessary rights and the presentation of complete and correct information are the responsibility of the applicant and their representatives and the failure to do so, including the failure or the inability to attain all necessary permits, licenses, releases, easements, or rights-of-way may constitute a reason for disapproval or rescission of approval of a plan and for other actions provided for by law.

### **C. Conveyance of Utilities**

If accepted by the Board of Selectmen, and if necessary, voted in the affirmative by Town Meeting, the developer may execute an instrument transferring to the Town valid, unencumbered title to all sanitary sewers, stormwater pipes, structures and appurtenances thereto constructed and installed in the entire subdivision or in connection with any lot thereof, whichever is applicable, and convey to the Town, without cost and free of all liens and encumbrances, perpetual rights and easements to construct, inspect, repair, renew, replace, operate and forever maintain such sanitary sewers, storm water systems and all appurtenances thereof and to do all acts incidental thereto in, through and under the whole of streets in the subdivision and, if such sewers and/or storm water systems have been constructed and installed in land easements, as shown on the definitive plan, or where no easements are shown, in, through and under a strip of land extending 10 feet in width on each side of the centerline of all such sanitary or storm water systems.

The above shall not be construed to relieve the developer and their successors in title to a portion of land or street in the subdivision of responsibility to complete all construction, as required by the developer's covenants and agreements with the Town, and to thereafter maintain all streets and utilities in a satisfactory condition until they are accepted by the Town. The Town of Wareham does not automatically accept streets and assume maintenance responsibility upon

release of a developer's bond. In fact, the town will attempt first to have the homeowners take responsibility for the road and utilities, and to further limit the town's acceptance of certain elements of the infrastructure. Such transfer shall be valid only if authorized by appropriate Town Meeting action to accept said transfer of facilities or systems.

Water mains shall not be conveyed to the Town, but may be conveyed to the applicable Water District, subject to the most recent By-Laws of the Onset Fire District or Wareham Fire District, whichever the case may be.

**D. Ownership of Ways or Easements**

The subdivider shall retain title to the fee of each street, path, or easement in or appurtenant to the subdivision until conveyed to the Town or for at least three (3) years after completion of improvements, whichever is the lesser. Notation that this is to be done shall be placed on the definitive plan. This provision may be waived by the Planning Board for subdivisions where the public interest is served by retention of private ways and means of securing such retention and their maintenance have been agreed upon.

Security in an amount equal to at least 15% of the total cost of street construction shall be retained to ensure construction adequacy against hidden faults and shall not be released until the fee has been conveyed as indicated above or until three (3) years have lapsed since completion of improvements.

A Home Owners Association may be required to be established in the subdivision to transfer to and assume ownership and maintenance of the subdivision improvements.

**E. Definitions**

**Applicant:** Shall include an owner or their agent or representative or assigns.

**Board:** Shall refer to the Wareham Planning Board.

**Certified:** "Certified by (or endorsed by) a planning board", as applied to a plan or other instrument required or authorized by the Subdivision Control Law to be recorded, shall mean bearing a certification or endorsement signed by a majority of the members of the Planning Board or by its Chair or Clerk or any other person authorized by it to certify or endorse its approval or other action and named in a written statement to the Plymouth County Registry of Deeds and recorder of the Land Court, signed by a majority of the Board. Also applies to certification by a professional designer that construction completed is in compliance with the Subdivision Rules & Regulations.

**Definitive Plan:** Shall mean a plan of a subdivision meeting the requirements of these Subdivision Rules and Regulations for submission, with appropriate and complete application, submitted to the Board for approval, to be recorded in the Plymouth County Registry of Deeds or filed with the Land Court when approved by the Board, all as distinguished from a preliminary plan.

**Drainage:** Shall mean the control of surface water within the tract of land to be subdivided.

- Driveway:** An open space located on a lot that provides access to a garage or off-street vehicle accommodation area.
- Lot:** Shall mean an area of land in one (1) ownership with definite boundaries used, or available for use, as the site of one (1) or more buildings.
- Lot Frontage:** The boundary of a lot coinciding with a street line if there are both rights of access and potential vehicular access across that boundary.
- Municipal Service:** Shall mean public utilities furnished by the city or town in which a subdivision is located, such as water and sewer. Also includes, gas and electricity.
- Preliminary Plan:** Shall mean a plan of a proposed subdivision or re-subdivision of land drawn on tracing paper, or a print thereof, showing (a) the subdivision name, boundaries, north point, date, scale, legend and title "Preliminary Plan"; (b) the names of the record owner and the applicant and the name of the designed, engineer or surveyor; (c) the names of all abutters, as determined from the most recent local tax list; (d) the existing and proposed lines of streets, ways, easements and any public areas within the subdivision in a general manner; (e) the proposed system of drainage, including adjacent existing natural waterways, in a general manner; (f) the approximate boundary lines of proposed lots, with approximate areas and dimensions; (g) the names, approximate location and widths of adjacent streets; (h) and the topography of the land in a general manner.
- Recorded:** Shall mean recorded in the Registry of Deeds of the county or district in which the land in question is situated, except that, as affecting registered land, it shall mean filed with the recorder of the Land Court.
- Subdivision:** Shall mean the division of a tract of land into two (2) or more lots and shall include re-subdivision and, when appropriate to the context, shall relate to the process of subdivision or the land or territory subdivided; provided, however, that the division of a tract of land into two (2) or more lots shall not be deemed to constitute a subdivision within the meaning of the Subdivision Control Law if, at the time when it is made, every lot within the tract so divided has frontage on (a) a public way or a way which the Clerk of the Town certifies is maintained and used as a public way, or (b) a way shown on a plan theretofore approved and endorsed in accordance with the Subdivision Control Law, or (c) a way in existence when the Subdivision Control Law became effective in the town having, in the opinion of the Planning Board, sufficient width, suitable grades adequate construction to provide for the needs of vehicular traffic in relation to the proposed use of the land abutting thereon or served thereby and for the installation of municipal services to serve such land and the building erected or to be erected thereon. Such frontage shall be of at least such distance as is required by zoning for erection of a building on such lot. Conveyances or other instruments adding to, taking away from, or changing the size and shape of, lots in such a manner as not to leave any lot so affected without the frontage above set forth, or the division of a tract of land on which two (2) or more buildings were standing when the Subdivision Control Law went

into effect into separate lots on each of which one (1) of such buildings remains standing, shall not constitute a subdivision.

Subdivision Control Law: Massachusetts General Laws, Chapter 41, Sections §81K to 81GG inclusive.

**F. Modification, Amendment or Rescission**

The Planning Board, acting on its own motion or on the petition of any interested person, shall have the power to modify, amend, or rescind its approval of a subdivision plan, or to require a change in a plan as a condition of its retaining the status of an approved plan. All of the provisions of the Subdivision Control Law relating to the submission and approval of a plan of a subdivision shall, so far as apt, be applicable to the approval of the modification, amendment or rescission of such approval and to a plan which has been changed under this Section.

**G. Reference**

For matters not covered by these Rules and Regulations, reference is made to Massachusetts General Laws, Chapter 41, §§ 81K to 81GG, inclusive.

**H. Severability**

If any provision of these Rules and Regulations is found to be invalid or void, it shall not affect any other provision of these Rules and Regulations.

**I. Waiver**

Requests for waivers from requirements of any section of these Rules and Regulations shall be submitted in writing to the Planning Board at the time of application and shall be properly voted on by the Board. If granted, said waiver(s) shall be issued in writing by the Planning Board.

**Section II – Approval Not Required Plans**

**A. Criteria**

Any owner of land located in the Town of Wareham who believes that a plan of said land does not constitute a subdivision, as defined herein, and thus does not require approval under the Subdivision Control Law per Chapter 41, §81P and, who desires to record said plan with the Plymouth County Registry of Deeds or the Land Court, may submit said plan for Certification/endorsement by the Planning Board. The following standards must be met in order for a lot shown on said plan to be entitled to endorsement as a lot.

Planning Board approval is not required for a division of land when the lots shown on the plan have adequate access and frontage (as defined below) on:

- a) A way that the Town Clerk certifies is maintained and used as a public way; or
- b) A way shown on a plan that was previously approved in accordance with the Subdivision Control Law; or
- c) A way in existence prior to May 11, 1951, having in the opinion of the Planning Board, sufficient width, suitable grades and adequate construction to provide for the need of vehicular traffic in relation to the proposed use of the land abutting thereon or served thereby.

No plan shall be endorsed as not requiring approval under the Subdivision Control Law unless each building lot to be created has adequate access as intended under the Massachusetts General Laws, Subdivision Control Law, Chapter 41, §81M. Each building lot to be created shall have frontage of such distance as is required in the Zoning By-Laws at the time of plan submission. Such frontage shall provide both rights of access and potential vehicular access across that boundary.

When re-dividing property, care must be taken by the applicant to ensure that a new zoning violation is not created. The Board cannot vacate violations through its endorsement of a plan. This is the responsibility of the applicant.

## **B. Submission of Plans**

The applicant shall file two (2) originally-signed Form A applications, one (1) original -plan and six (6) contact prints and a digital file copy of the original plan with the Planning Department with a properly executed Form A application conforming to the requirements of §II.C. and as specified on the Application either in person or by certified mail. All owners of any land included in such plan shall be co-applicants. The Planning Board may require a Deed or other acceptable verification of ownership. The required application fee (as set forth in the fee schedule provided in §VII of the Subdivision Rules and Regulations) and the Town Treasurer's Certification shall be included as part of the submission.

Once the application is considered complete by Planning Board staff, it shall be placed on the next available Planning Board agenda for filing with the Board.

Following the filing of the plan with the Board, Planning Board staff shall then file one copy of the application with the Town Clerk bearing the Planning Board's stamp of receipt containing the date and time of filing.

## **C. Plan Contents**

The plan submitted shall be suitable for recording with the Plymouth County Registry of Deeds. The plan shall contain the following information:

1. The title, "Approval Not Required Plan Drawn For (Name of Owner)";
2. Name of record owner(s) of land shown on the plan;
3. Date, scale and north arrow;
4. Name, signature and seal of surveyor who prepared the plan;
5. Zoning district, tax assessor's map and lot number(s) and the location of any zoning district boundaries that may be within the locus of the plan;
6. A locus at a scale of approx. 1" = 2000', or sufficient to accurately identify where the property is located within the Town;
7. Name(s) of the present owner of the land and the name(s) of the abutter(s) as they appear on the most recent Assessor's records. If the applicant has knowledge of any changes subsequent to the most recent Assessor's records, they shall provide the name(s) of the present land owner(s) to the Planning Board;
8. Location of all abutting land owned by the applicant not presently being subdivided;
9. Any remaining frontage of adjoining land in the same ownership as the subject parcel(s);
10. Any existing structures on adjoining land in the same ownership as the subject parcel;
11. Location of all man-made structures and significant natural features on the subject parcel(s) and significant natural features including existing buildings and

structures, stone walls, rock outcrops, steep slopes, delineation of wetland resource areas (as approved by the Conservation Commission), easements, rights of way, water courses, drains, streets, ways, scenic roads, major trees (12-inch diameter or larger) and such other references known to the applicant to sufficiently identify any existing impediments to access upon the land. A topographic plan, at two (2)-foot contours, shall be provided where slopes exceeding 15% will impede access upon the land between the street and the proposed location of the structure or house.

12. Boundary lines, dimensions, bearings, distances and areas of all lots to which the plan relates;
13. Delineation of all streets and ways, both sides, indicating the width of pavement with a statement of whether or not all streets and ways shown or referred to are public or private ways, indicating the same as to each street or way so shown;
14. In the case of streets or ways that are not certified by the Town Clerk as maintained by the Town of Wareham as a public way, or a way not previously approved under the Subdivision Control law, the width of the existing traveled way, grade of the traveled way and details of existing construction shall be noted on the plan.
15. Notice of any decision by the Zoning Board of Appeals, including but not limited to variances and exceptions or special permits pertaining to the land or any buildings thereon;
16. The statement “Approval Under the Subdivision Control Law Not Required” together with sufficient space for the signatures of the required number of Board members and the date of endorsement;
17. The following notes shall appear on the plan [*italics not required*]:

*This endorsement of the Planning Board should not be construed to be a determination of conformance with zoning regulations for all lots affected. This endorsement of the Planning Board should not be construed to be a determination of conformance with the Wareham Town By-Laws in accordance with Division VI, Article I and its implementing wetlands protection regulations as well as Massachusetts Wetlands Protection Act, M.G.L. Ch. 131, §40 and its implementing regulations, 310 CMR 10.00 for all lots affected.*

*This endorsement of the Planning Board should not be construed to be a determination of conformance with the Zoning By-Law relative to Irregularly-Shaped Lots, Upland Area, Lot Width, Open Space and Lot Coverage in accordance with Article 10; Article 6, §615; Article 6, §612; Article 6, §620 for all lots affected.*

*This endorsement of the Planning Board should not be construed to be a determination of conformance with the Earth Removal Regulations in accordance with Division IV, Article III of the Town By-Laws for all lots affected.*

18. On any plan wherein the Board deems it necessary or consistent with the purpose and intent of these Rules and Regulations or wherein additional information is necessary for the Board to make a determination of “Approval Not Required,” such additional information as the Board may so request.

**D. Endorsement of Approval Not Required Plan**

1. If the Board determines that the plan does not require approval under the Subdivision Control Law, the Board shall forthwith and without a public hearing endorse the plan within 21 days upon submission of the plan to the Planning Board and Town Clerk. The original mylar plan shall be returned to the applicant upon endorsement and the Board shall retain copies of the endorsed plan as a digital file for its records.
2. If the Board determines that, in its opinion, the plan requires approval under the Subdivision Control Law, it shall give written notice of its determination to the Town Clerk and the applicant within 21 days of submission of the plan to the Town Clerk [after acceptance by the Planning Board] stating the reason for said denial. The applicant then has the option of filing a preliminary or definitive subdivision plan with the Planning Board.
3. If the Board fails to act upon a plan submitted under this section or fails to notify the Town Clerk and the applicant of its action within 21 days upon submission of the plan to the Town Clerk [after acceptance by the Planning Board], the plan shall be deemed to have determined that approval under the Subdivision Control Law is not required and it shall forthwith make such endorsement on said plan; and on its failure to do so forthwith, the Town Clerk shall issue a certificate to the same effect.

**Section III – Preliminary Subdivision Plans**

**A. Purpose**

A preliminary plan of any residential subdivision may be submitted to the Planning Board for discussion and approval, modification or disapproval. Submission of a preliminary plan is strongly recommended to provide for detailed review of the layout and features of the proposed subdivision by the Planning Board and other Town boards and to minimize the need for major changes of the definitive plan. As of April 7, 1987, all proposed non-residential subdivisions are **REQUIRED** to submit a preliminary plan.

**B. Submission of Preliminary Plan**

Any person who wishes to file a preliminary plan shall submit a complete and accurate application form and all plans and information as herein required by these Rules and Regulations to the Planning Board at a regularly-scheduled meeting or by registered mail in care of the Town Clerk.

The applicant shall file:

1. A properly executed copy of **Form B** that shall include the following with the Town Clerk:
  - a. The date on which the plan was submitted to the Planning Board;
  - b. A description of the land to which the plan is related sufficient for identification;
  - c. The name and address of the owner of the land;
2. With the Planning Board:
  - a. Two (2) properly executed copies of Form B;
  - b. Ten (10) contact prints of the original preliminary plan;



- c. One e-file copy of all submittals;
- d. Filing fee – *See Section VII*

- 3. With the Board of Health:
  - a. One (1) copy of the preliminary plan.

An application is deemed **NOT** submitted if it does not comply with the requirements of Section III-B and Section III-C of these Rules and Regulations.

### **C. Plan Contents**

The preliminary plan shall be drawn on reproducible substrate and shall show sufficient information about the subdivision to form a clear basis for discussion of its problems, if any, and for the preparation of the definitive plan. Such information shall show at least the following:

- 1. The title, “Preliminary Plan of (Name of Subdivision)”;
- 2. Date, scale, north point, tax assessor’s map and lot number(s) and, if appropriate, a legend to explain any graphic representation or symbol(s) on the plan;
- 3. The names of the record owner and the applicant;
- 4. The name(s) of the designer, engineer or surveyor who prepared the plan;
- 5. The name(s) of all abutters, as determined from the most recent local tax list;
- 6. The existing and proposed lines of streets, ways, easements and any public areas within the subdivision in a general manner;
- 7. The proposed system of drainage including adjacent existing natural waterways in a general manner;
- 8. The approximate boundary lines, dimensions and areas of proposed lots;
- 9. The names, approximate location and width(s) of adjacent streets;
- 10. The topography of the land in a general manner but of sufficient detail to allow the Board to make a reasonable determination as to the adequacy of the drainage design concept;
- 11. The location of and distance to the nearest public water and sewer utility services.

### **D. Procedures**

The Planning Board shall advertise a public meeting to review the Preliminary Plan and make findings and recommendations. A public hearing shall be called at the discretion of the Planning Board.

### **E. Review by Other Boards and Departments**

Once the preliminary plan has been properly submitted and accepted, the Planning Board shall send a copy of the preliminary plan to the following:

- 1. Conservation Commission;
- 2. Municipal Maintenance Department;
- 3. The respective Fire Department;
- 4. Sewer Commissioners;
- 5. The respective Water Department;
- 6. Building Commissioner.

Failure of any board or department to submit a written report with recommendations within 30 days after receipt of the Planning Board’s letter requesting its input shall mean it has no problem with the plan unless an extension of time is requested.

The Board of Health files its own report stating whether it approves, approves with modifications or disapproves the plan in accordance with Massachusetts General Laws, Chapter 41, §81S. Failure of the Board of Health to report in writing within 45 days after the date of submittal shall be deemed its approval of the plan.

#### **F. Decision of the Planning Board**

Within 45 days after the submission of the preliminary plan, the Board shall notify the applicant and the Town Clerk whether said plan has been approved, approved with modifications or disapproved. Such tentative approval does not constitute approval of a subdivision, but does facilitate the procedure in securing final approval of the definitive plan. For all non-residential subdivisions, the Planning Board shall determine street classification and minimum width of the right-of-way at the preliminary plan stage.

No Registrar of Deeds shall record a preliminary plan.

### **Section IV – Definitive Subdivision Plans**

#### **A. Submission of Definitive Subdivision Plan**

Any person who wishes to file a definitive subdivision plan shall submit a complete and accurate application form and all plans and information as required herein by these Rules and Regulations to the Planning Board at a regularly scheduled meeting or by registered mail in care of the Town Clerk. If so mailed, the date of mailing shall be the date of submission of the plan.

The applicant shall file:

1. A properly executed copy of Form C that shall include the following with the Town Clerk:
  - a. The date on which the plan was submitted to the Planning Board;
  - b. A description of the land to which the plan is related sufficient for identification;
  - c. The name and address of the owner of the land.
  
2. With the Planning Board:
  - a. Two (2) properly executed copies of Form C;
  - b. Six (6) contact prints of the definitive plan;
  - c. Two (2) copies of a list of abutters to be certified by the Board of Assessors indicating all owners of land abutting the definitive plan locus, together with the address of each as determined from the most recent tax list;
  - d. Two (2) copies of the deed(s) of the property to be subdivided;
  - e. Filing fee – *See Section VII*;
  - f. A receipt from the Board of Health that a copy of the plan has been filed with that board;
  - g. A digitized file copy of all submitted materials.
  
3. With the Board of Health:
  - a. A copy of the definitive plan.

An application is deemed NOT submitted if it does not comply with the requirements of Section IV-A and Section IV-B of these Rules and Regulations.

#### **B. Plan Contents**

The definitive plan shall be prepared by a Registered Engineer or Registered Land Surveyor and shall be clearly and legibly drawn in black ink upon mylar. The plan shall be at a scale of

one (1) inch equals 40 feet (1"=40') or such other scale as the Board may accept to show details clearly and adequately. The prints are to be dark-line on white background and sheet sizes shall not exceed 24" x 36". If multiple sheets are required to adequately detail a large subdivision, they shall be accompanied by an index sheet showing the entire subdivision. The definitive plan shall be suitable for recording with the Plymouth County Registry of Deeds and shall contain at least the following:

1. The title: "Subdivision Plan of (Subdivision Name)";
2. The date, scale, north point, tax assessor's map and lot number(s) and, if appropriate, legend to explain any graphic representations or symbols on the plan;
3. The name and address of the present owner(s) and applicant(s);
4. The name, address, signature and seal of the Registered Professional Engineer or Registered Land Surveyor who prepared the plan;
5. The names of all abutters as they appear in the most recent tax list, including property owners on the opposite side of any streets abutting the subdivision locus;
6. Book and page deed reference(s) of the property to be subdivided;
7. A note referring to which lots will be served by either Town water supply, private wells, municipal sewer or private septic systems and the location of the nearest existing public water and sewer utility services;
8. A locus plan at the scale of approximately one (1) inch equals two-thousand feet (1"=2,000') showing the boundaries of the proposed subdivision, location of proposed streets and relation to adjoining properties within a radius of ¼ mile;
9. The zoning district, including any overlay district, of the land shown on the plan;
10. The location of all wetlands on the subject property and within 100 feet of the property boundary as defined by 310 CMR 10.00 Wetlands Protection and the Wareham Wetlands By-Law, Division VI. If protected wetlands are to be filled, the plan shall show the area (in square feet) to be filled and, if required by the Wetlands Protection Act, the location and area (in square feet) of replacement wetlands;
11. Sufficient data to readily determine the location, direction and length of every street, way, easement, lot and boundary line and to establish those lines on the ground. The areas of all lots shall be shown and all lots shall be numbered. All bearings are to be referred to Massachusetts Prime Meridian if reference points are within a reasonable distance;
12. The location, names and present widths of streets bounding, approaching or within reasonable proximity of the subdivision;
13. Location of all permanent monuments, properly identified as to whether existing or proposed and the location of temporary stakes to enable the Planning Board to find and appraise features of the subdivision plan in the field;
14. Street names to be approved by the Planning Board and 911 Coordinator to prevent duplication and to provide names in keeping with the character of the Town;
15. A street number in accordance with the provisions of Division II, Article I, House Numbering By-Law of the Town of Wareham, the and approved by Assessor;
16. Notation, as required by Section 1-D, Ownership of Ways or Easements;
17. Any public or common areas within the subdivision;
18. Location of all abutting land owned by the applicant not presently being subdivided;
19. A suitable bracket to record the action of the Planning Board and the signatures of the members of the Board.

20. A suitable bracket for the Town Clerk's signature, along with the statement, "I hereby certify that 20 days have elapsed since the Notice of Approval from the Planning Board was received and recorded and no Notice of Appeal has been filed in this office".
21. A list of all requested waivers from the literal requirements of these Rules and Regulations.

Items 22 through 29 below shall be submitted on additional sheets of the same size and material as the first sheet and each additional sheet shall bear a title block and signature block as required in Section IV.B.1, 2 and 4.

22. Contour Plan showing existing and proposed topography at two (2)-foot intervals related to an existing permanent benchmark. In instances where clarity or finer detail is necessary for the proper evaluation of the project, the Board may at its own discretion require that contours shall be done to a one-foot interval.
23. Utility Plan showing in plan and profile, but not limited to, the size and location of existing and proposed water and sewer lines, hydrants, electric lines, telephone lines, gas mains, cable television line and storm drains and any easements pertinent thereto;
24. Drainage Plan showing existing and proposed streets, lots, two foot (2') contours or other interval as required by the Board and other pertinent data; the drainage limits and acreage of the area tributary to each stormwater inlet and culvert; location and type of inlets proposed; location, size, length, invert elevations and slope of proposed drains and culverts; structural details of inlets, manholes, pipes, headwalls and all other drainage structures required to complete the plan  
  
In calculating the runoff and drainage requirements, consideration shall be given to the impact on the area's hydrogeology as well as any upstream runoff that may impact on the subdivision;
25. Street Plans and Profiles at a horizontal scale of one (1) inch equals 40 feet (1" = 40') and a vertical scale of one (1) inch equals four (4) feet (1" = 4') or such other scale as the Planning Board may approve. The following information shall be included:
  - a. The exterior lines of the proposed way(s) with sufficient data to determine location, direction and length;
  - b. The existing centerline profile shall be shown as a fine, continuous line. The existing centerline profile for intersecting streets shall be shown for at least 100 feet of each side of the intersection of street centerlines. The proposed right sideline shall be shown as a dashed black line and the left sideline shall be shown as black dots. Elevations shown shall be based on U.S.G.S. datum;
  - c. The proposed centerline profile shall be shown as a heavy continuous line with elevations based on U.S.G.S. datum shown every 50 feet (50') and every 25 feet (25') on vertical curves;
  - d. The road centerline stationing shall be shown.
26. A typical section showing proposed roadway construction at a scale of one (1) inch equals 10 feet (1" = 10') shall be provided with the profile plan (See Appendices)
27. Street Lights and a Tree Plan shall be provided for the area within the proposed street right-of-way to show the following:
  - a. Existing trees to be preserved within the right-of-way;
  - b. Any proposed street trees;
  - c. Existing and proposed street lights.

28. The developer shall submit a Soil Erosion and Sedimentation Control Plan. This Plan shall consist of a drawing certified by a Registered Civil Engineer identifying appropriate control measures and their locations, for temporary, during construction and permanent measures, designed in accordance with the State Stormwater Handbook
29. If necessary in order to determine compliance with these *Rules & Regulations*, the Planning Board may require further engineering or environmental analysis to be prepared at the expense of the applicant, employing professionals approved by the Planning Board.
30. A complete stormwater analysis or report shall accompany the plan submittal in the form of a written document outlining all pre-construction conditions and post-construction conditions in accordance with the Massachusetts Stormwater Handbook. The analysis shall include the following as a minimum:
  - a. Tabulation of soil tests conducted for all surface and subsurface infiltration facilities associated with the appropriate drainage design,
  - b. Stormwater calculations for the 2-year, 10-year, 25-year and 100-year storm events.
31. To meet stormwater goals for water quality, all new and redevelopment projects that disturb a minimum of 1 acre of land, or projects that are part of a common plan of development that disturb a minimum of 1 acre of land total, must include stormwater management systems designed in compliance with the Massachusetts Stormwater Handbook (or be more stringent than those standards); and provide reductions in Total Phosphorus and Total Suspended Solids (TSS) in post-construction stormwater runoff as follows:
  1. New development: 90% removal of average annual load of TSS and 60% removal of average annual load of Total Phosphorus
  2. Redevelopment: 80% removal of average annual load of TSS and 50% removal of average annual load of Total Phosphorus

#### **C. Review by the Board of Health**

When a Definitive Plan of a subdivision is submitted to the Planning Board, a copy thereof shall also be filed with the Board of Health. The Board of Health, within 45 days after the plan is filed, shall report to the Planning Board; in writing, approval or disapproval of said plan and in the event of disapproval, will make specific findings as to which; if any, of the lots shown on such plan cannot be used for building sites without injury to the public health and include such specific findings and the reasons therefore in such a report and, where possible, will make recommendations for the adjustments thereof provided; however, if a municipal sewer system will service the proposed subdivision, then failure of the Board of Health to make such a report within 45 days after the plan is filed with its office shall be deemed approval of the Board of Health. The Board of Health shall send a copy of such report; if any, to the applicant that submitted said plan.

If the report of the Board of Health shall so require, the approval by the Planning Board shall be on the condition that no building or structure shall be built or placed upon the areas designated without the consent of the Board of Health.

#### **D. Notification and Public Hearing**

No action may be taken by the Planning Board on a Definitive Plan until a public hearing on such Definitive Plan has been held. Notice of date, time and place of hearing and the subject matter sufficient for identification shall be given by:

1. The Planning Board, at the expense of the applicant, by advertising in a newspaper of general circulation in the Town in each of two (2) successive weeks. The fee for advertising shall be paid directly by the applicant to the advertiser. The first publication shall be not less than 14 days before the date of the public hearing. The Planning Board shall mail a copy of the advertisement to the applicant;
2. The applicant, by sending notices prepared by the Planning Office, to abutters by Certified Mail, Return Receipt Requested. Return receipts are to be addressed to the applicant. The applicant must present the return receipts to the Planning Board and they must match the list of abutters certified by the Board of Assessors prior to the opening of the public hearing.

**E. Approval, Modification or Disapproval of Plan**

After the public hearing as provided in M.G.L., Chapter 41, § 81T and after the report of the Board of Health or the lapse of 45 days without such report, the Planning Board shall approve, modify and approve or disapprove plans as follows:

1. Non-Residential Subdivisions

Final approval, modification or disapproval of a Definitive Plan for a non-residential subdivision shall be within 90 days after such submission or such further time as may be agreed upon at the written request of the applicant. Notice of such extension of time shall be filed forthwith by the Planning Board with the Town Clerk.

2. Residential Subdivisions

- a. Final approval, modification or disapproval of a Definitive Plan for a residential subdivision where a Preliminary Plan has been duly submitted shall be within 90 days after such submission or such further time as may be agreed upon at the written request of the applicant. Notice of such extension of time shall be filed forthwith by the Planning Board with the Town Clerk;
- b. Final approval, modification or disapproval of a Definitive Plan for a residential subdivision where a Preliminary Plan has NOT been duly submitted shall be within 135 days after submission or such further time as may be agreed upon at the written request of the applicant. Notice of such extension of time shall be filed forthwith by the Planning Board with the Town Clerk.

In the event of disapproval, the Planning Board shall state in detail wherein the plan does not conform to these Rules & Regulations or to the recommendations of the Board of Health and shall revoke its disapproval and approve a plan which; as amended, conforms to such Rules & Regulations or recommendations. The Planning Board shall file a certificate of its action with the Town Clerk, a copy of which shall be recorded for that purpose and shall send notice of such action by registered mail, postage prepaid, to the applicant at the address stated on the application.

Final approval, if granted, shall be endorsed on the original drawing of the Definitive Plan by the signatures of a majority of the Planning Board, but not until the statutory 20-day appeal period has elapsed following the filing of the Planning Board's *Certificate of Approval* with the Town Clerk and said Clerk has notified the Planning Board that no appeal has been filed. If appeal has been made, said endorsement shall be made after the entry of a final decree of the court sustaining the approval of such plan.

## **F. Performance Guarantee**

Prior to endorsement of the Approval of a Definitive Plan, the Planning Board shall require that the construction of the ways, the installation of municipal services and the performance of other applicable provisions of Sections V and VI in accordance with the these Rules & Regulations be secured by one, or by more than one, of the methods described in the following clauses which method or combination of methods may be selected and, from time to time, varied by the applicant:

1. By a proper bond that is sufficient, in the opinion of the Planning Board, to secure performance of the construction of ways and the installation of municipal services required for lots in the subdivision shown on the plan. The Planning Board may require that the applicant specify the time within which such construction shall be completed.
2. By a deposit of money or negotiable securities sufficient, in the opinion of the Planning Board, to secure performance of the construction of ways and the installation of municipal services required for lots in the subdivision shown on the plan. The Planning Board may require that the applicant specify the time within which such construction shall be completed.
3. By a covenant executed and duly recorded by the owner of record, running with the land, whereby such ways and services shall be provided to service any lot before such lot may be built upon or conveyed, other than by mortgage deed, provided that a mortgagee that acquired title to the mortgaged premises by foreclosure or otherwise and any succeeding owner of such premises or part thereof, may sell any such lot, subject to that portion of the covenant that provides that no lot shall be built upon until such ways and services have been provided to serve such lot and provided further that nothing herein shall be deemed to prohibit a conveyance by a single deed, subject to such covenant, of either the entire parcel of land shown on the subdivision plan or of all lots not previously released by the Planning Board. A deed of any part of the subdivision in violation hereof shall be voidable by the grantee prior to the release of the covenant but no later than three (3) years from the date of such deed.
4. By an agreement delivered to the Planning Board and executed after the recording of a first mortgage covering the premises shown on the plan or a portion thereof given as security for advances to be made to the applicant by the lender, which agreement shall be executed by the applicant and the lender and shall provide for the retention of the lender of funds sufficient, in the opinion of the Planning Board, and otherwise due the applicant, to secure the construction of ways and the installation of municipal services. Said agreement shall also provide for a schedule of disbursements that may be made to the applicant upon completion of various stages of the work and shall further provide that, in the event the work is not completed within the time set forth by the applicant, any funds remaining undisbursed shall be available for completion.
5. Any covenant given under the preceding paragraph and any condition required by the Board of Health shall be either inscribed on the plan or contained in a separate document and referred to on the plan.
6. The penal sum of any such bond held under clause #1 or any deposit held under clause #2 or any amount of funds retained pursuant to an agreement under clause #4 shall bear a direct and reasonable relationship to the expected cost including the effects of inflation, necessary to complete the subject work. Such a value shall typically be 125% of the expected cost of construction. Such amount(s) shall, from time to time, be reduced so that the amount bonded, deposited or retained continues to reflect 125% of the expected cost of work remaining to be completed.

7. Upon the completion of the construction of ways and the installation of municipal services in accordance with Sections V and VI of these Rules and Regulations, security for the performance of which was given by bond, deposit or covenant with respect to any lot, the applicant shall send by registered mail to the Town Clerk and the Planning Board a written statement that the said construction or installation in connection with which such bond, deposit or covenant was given has been completed in accordance with Sections V and VI. Such statement shall contain the address of the applicant. If the Planning Board determines that said construction or installation has been completed, it shall release the interest of the Town in such bond and return the bond or the deposit to the person that furnished the same or release the covenant by appropriate instrument; duly acknowledged, which may be recorded.
8. Such bond, deposit, covenant or agreement shall be contingent on the completion of such ways, services and other provisions of Sections V and VI of these Rules & Regulations within 24 months from the date of approval of the Definitive Plan.
9. The construction of all ways and the installation of all municipal services shall be completed in accordance with the applicable Rules & Regulations contained herein within 24 months from the date of approval of the plan. Failure to so complete shall automatically rescind approval of the plan.

#### **G. Recording**

The applicant shall file the approved Definitive Plan and covenant; if any, with the Plymouth County Registry of Deeds and shall notify the Planning Board; in writing, presenting evidence of the recording of the plan and covenant. The applicant shall deliver to the Planning Board two (2) copies and one digital file of the approved and recorded Definitive Plan and Covenant.

#### **H. Inspection**

Prior to the commencement of construction, the applicant shall deliver to the Director of Municipal Maintenance and to the Town Engineer or Board's Consulting Engineer a complete set of the approved and signed plans including road profiled and construction details together with a copy of the Certificate of Approval and Road Covenant and, in the absence of a covenant, proof of other road construction security that has been approved by the Planning Board.

Inspection of construction by the Director of Municipal Maintenance and/or the Town Engineer or Board's Consulting Engineer is required for completion of the streets and utilities installed therein together with any adjacent easements for all subdivisions approved by the Planning Board.

The applicant is responsible for requesting and attaining inspections by first notifying the Director of Municipal Maintenance and the Town Engineer or Board's Consulting Engineer of their intent to commence work. Inspections will be carried out in conformance with the provisions of

**Site Inspection Procedures for the Town of Wareham Planning Board dated  
December, 2019**

found in Section VIII of these Rules & Regulations.

The applicant shall attain and use Form N to keep a record of inspections and to secure the signature of the inspector(s) at the appropriate time in the construction process. Should an inspection not be performed due to the failure of the applicant to arrange for an inspection with the Director of Municipal Maintenance or Town Engineer or Consulting Engineer in a timely manner, the applicant will be required to uncover the improvements and make appropriate arrangements for an inspection.



No work will be accepted that has been covered prior to inspection or that does not meet the requirements of these Rules & Regulations.

At a minimum, inspections are required at the following times during the construction process and in compliance with the Site Inspection Procedures referenced above:

1. First Inspection:

After the roadway has been cleared and grubbed and drainage, sewer and water lines have been installed but prior to backfilling. More than one (1) inspection may be required to facilitate the construction process and to ensure that all work has been approved.

2. Second Inspection:

During the placement of road base materials and again when road base material is being compacted and fine-graded in preparation for paving.

3. Third Inspection:

After pavement has been placed, the shoulders are loamed and seeded, the monumentation is set, the street sign(s) are in place and final cleanup has been completed. The entire area, including any disturbed areas outside the street limits must be cleaned so as to leave a neat and orderly appearance free from debris and other objectionable materials. All disturbed areas shall be dressed in accordance with the approved plan.

4. Final Inspection

An 'as-built' plan shall be prepared and submitted to the Board prior to final inspection.

Upon final inspection, a completed Form N shall be submitted to the Planning Board by the applicant. No lots, not previously released in accordance with Section IV.C, Performance Guarantee, shall be released until the Form N has been submitted and approved by the Planning Board.

## **Section V – Design Standards**

### **A. General**

The proposed subdivision shall be so designated as to protect the health, safety, convenience and welfare of the occupants of the subdivision and the Town of Wareham. The design shall:

1. Reduce, to the extent reasonably possible, the following:
  - a. Volume of cut and fill;
  - b. Area over which existing vegetation will be disturbed, especially if within 100 feet of a river, pond or other body of water;
  - c. Number of mature trees removed;
  - d. Disturbance of natural drainage patterns or increase in peak rates of stormwater transport from the site;
  - e. Disturbance of important wildlife habitats and scenic or historic resources;
  - f. Visual prominence of man-made elements not necessary for safety or orientation;
  - g. The impact to the abutting neighborhood.
2. Increase to the extent reasonably possible, the following:
  - a. Visual prominence of natural features of the landscape;
  - b. Vistas and water views from public ways.

## **B. Stormwater Management and Drainage**

1. Design
  - a. Design of the drainage system shall, to the extent practicable, conform to the natural contours and drainage patterns of the site. To the maximum extent feasible, storm water shall be recharged to the ground on-site rather than piped off the site.
  - b. Connection to any existing public drainage systems will be permitted only if, in the opinion of the Director of Municipal Maintenance and Town Engineer or Board's Consulting Engineer, the existing system has adequate capacity to receive the additional storm water runoff.
  - c. An estimate of both the rate and volume of runoff prior to and after development shall be submitted along with supporting data. Calculations shall be presented for both pre-construction and post-construction conditions for the 2-year, 10-year, 25-year and 100-year storm events. In general storm water calculations shall be done in conformance with the requirements of the Commonwealth of Massachusetts Stormwater Handbook, latest edition.
  - d. The drainage system shall be designed so that peak run-off and stream flows at the boundaries of the development remain at pre-construction conditions.
  - e. No stormwater drainage system shall be designed that will adversely affect abutting properties or increase rates of runoff flow to downstream culverts or other structures.
  - f. The applicant's engineer shall so certify the above and the certification shall appear on the plan.
  - g. The Planning Board will not approve any design or component that, in its opinion, does not meet the standards of accepted engineering practice, will not function without frequent maintenance or is unsuited to the proposed character and use of the subdivision.
  - h. Lot boundaries shall be made to coincide with natural drainage ways and shall avoid the creation of lots that can be built upon only by altering such drainage ways so far as it is practical to do so.
  - i. Lots shall be prepared and graded in such a manner that development of one shall not cause detrimental drainage on another.
  - j. If a provision is necessary to carry drainage to or across a lot, an easement or drainage right-of-way of a minimum width of 20 feet shall be provided. The Planning Board may require the applicant to furnish evidence that adequate provision has been made for the proper drainage of surface and underground waters from any lot or lots. Storm water shall not discharge over land across lot lines unless adequately provided for as described above.
2. Stormwater design shall be in conformance with the standards set forth in the Massachusetts Storm Water Handbook, Volume 2, latest edition.

## **C. Streets**

1. Classification:

Subdivision streets shall be classified for the purpose of establishing the applicable design and construction standards according to the definitions below. The Planning Board shall determine the classification in all doubtful cases.

- a. Residential Minor Street – A street whose sole function is to provide access to abutting properties. It serves or is designated to serve no more than nine (9) dwelling units or nine (9) single-family lots.
- b. Residential Local Street - A street whose sole function is to provide access to abutting properties. It serves or is designated to serve at least 10 but no more than 25 dwelling units or single-family lots.
- c. Residential Standard Street – A street that is not intended for, nor does it have the potential for use by through traffic; rather, it will be used solely for access to lots located entirely within the subdivision. In the opinion of the Planning Board, said Standard Street will not serve a substantial amount of traffic.
- d. Residential Collector Street – A street that will be used to carry traffic not only from lots located within the subdivision, but will also be used to carry through traffic from other parts of town. In the opinion of the Planning Board, the potential exists for such streets to serve a substantial amount of traffic.

Once a classification has been determined and approved by the Planning Board, no additional dwelling units or single-family lots can be created with legal frontage on said street classification or its extension unless and until the road is redesigned and improved in accordance with the minimum standards heretofore prescribed for the various categories of residential streets. For all non-residential subdivisions, the street classification will be determined by the Planning Board at the Preliminary Plan submission.

2. Location and Alignment:

- a. All streets in the subdivision shall be designed so that, in the opinion of the Planning Board, they will provide safe vehicular travel;
- b. Provision satisfactory to the Planning Board shall be made for the proper projection of streets or for access to adjoining property that has the potential to be subdivided;
- c. Street jogs with centerline offsets of less than 125 feet shall be avoided;
- d. The minimum centerline radii of curved streets shall be 100 feet. Greater radii may be required for principal streets;
- e. Streets shall be laid out so as to intersect as nearly as possible at right angles. No street shall intersect any other street at less than 60 degrees;
- f. Property lines at street intersections shall be rounded or cut back to provide for a curb radius of not less than 30 feet. A greater radius may be required for major street intersections.

3. Street Width:

- a. The minimum width of the right-of-way shall be as follows:

|                              |         |
|------------------------------|---------|
| Residential Minor Street     | 40 feet |
| Residential Local Street     | 40 feet |
| Residential Standard Street  | 50 feet |
| Residential Collector Street | 65 feet |

- b. Greater widths of streets' rights-of way may be required by the Planning Board when deemed necessary;

- c. For all non-residential subdivisions, the street right-of-way width will be determined by the Planning Board at the time of submission.

4. Street Grade:

Grades of streets shall not be less than 0.75%. Grades shall not be more than 6% for principal streets or more than 9% for secondary streets.

5. Vertical Curve Alignment:

Grades for vertical alignment shall be tested for a passenger car to ensure safe passage.

6. Dead-End Streets:

Dead-end streets shall not be longer than 1,000 feet and shall be provided at the closed end with a turn-around having an outside roadway diameter of at least 100 feet and a property line diameter of at least 120 feet.

7. Adequate Access from a Public Way:

Where the streets within a subdivision do not connect with or have in the opinion of the Board, adequate access from a public way, the Board may require as a condition of approval, that such adequate access be provided by the applicant and/or that the applicant make physical improvements to and within such a way. If the Board finds that the public way is inadequate to accommodate the traffic expected from the subdivision, the Board may require a strip of land be dedicated to the purpose of improving capacity and safety of the roads. Any improvements to the public way must be approved by the agency that has jurisdiction over the way.

**D. Lots**

Lot frontage and area shall conform to the regulations of the Zoning By-Laws for the Town of Wareham and these Rules & Regulations.

**E. Easements**

1. Easements for utilities or any like purpose across lots, if necessary, shall be at least 20 feet in width.
2. Where a subdivision is traversed by a water course, drainage way, channel or stream, the Planning Board may require that there be provided a storm water easement or drainage right-of-way of adequate width to conform substantially to the line of such water course, drainage way, channel or stream and to provide for construction or other necessary purposes.

**F. Open Space**

Before approval of a plan the Planning Board may also, in proper cases, require that the plan show a park or parks suitably located for playground or recreation purposes or for providing light an air or access to shores or beaches. The park or parks shall not be unreasonable in area in relation to the land to be subdivided and to the perspective uses of such land. The Planning Board may, by appropriate endorsement on the plan, require that no building be erected upon such park or parks without its approval for a period of not more than three (3) years.

**G. Protection of Natural Features**

Water courses, marshes and like natural features shall be protected in accordance with the recommendations of the Wareham Conservation Commission. The attention of the applicant is directed to the provisions of M.G.L., Chapter 130, §105, "Coastal Wetland Act".

**Section VI – Required Improvements for an Approved Subdivision**

**A. Drainage**

Sizes, spacing and materials of drainage installations shall be determined by a registered professional engineer after first making a hydrologic study of the area being subdivided and shall be subject to the Planning Board’s approval. Catch basins shall be spaced along both sides of a street at approximately 400-foot intervals and located at all low points and corners at street intersections. All basins shall be connected by proper pipe not less than 12 inches inside diameter so as to provide a proper means for storm water runoff collection from the streets and area being drained. Leaching catch basins shall not be used under any circumstances.

Suitable alternative methods of the disposal of stormwater may be employed in areas other than subdivision streets, but only upon the Board receiving documentary evidence that standard catch basins and connecting pipe are not feasible or appropriate for the proposed use. These methods may include low impact design, infiltration structures or other methods as outlined in the Massachusetts Stormwater Handbook.

**B. Utilities**

1. Sewer pipes and necessary related equipment such as manholes and connecting ‘y’s” shall be constructed in conformance with the regulations of the Board of Sewer Commissioners and inspections shall be made by the Town Engineer, or the Board’s Consulting Engineer and the Director of Municipal Maintenance.
2. Water pipes and related equipment, such as hydrants and main shut-off valves, shall be constructed to serve all lots on each street in the subdivision in conformity with specifications of the Water Commissioners of the Wareham or Onset Fire Districts.
3. All utilities within a subdivision shall be placed underground. All utility lines shall be shown in plan and profile in the Definitive Plan as required by Section IV.B. Connections for all utilities from the main structures to the exterior line of the way shall be constructed for each lot whether or not there is a building thereon.
4. All subdivisions that are located within 1,500 feet of public sewer and/or water utilities shall be required to connect to such utility or utilities with infrastructure that is sufficiently sized to serve the needs of the proposed subdivision.

**C. Street and Roadway Construction**

1. Roadway pavement shall be constructed for the full length of all streets within the subdivision at the following widths (greater roadway pavement widths may be required by the Planning Board when deemed necessary):

|                              |         |
|------------------------------|---------|
| Residential Minor Street     | 18 feet |
| Residential Local Street     | 20 feet |
| Residential Standard Street  | 22 feet |
| Residential Collector Street | 24 feet |

2. For all non-residential subdivisions, the roadway pavement width will be determined by the Planning Board at the Preliminary Plan submission.
3. The entire area of each street or way shall be cleared of all stumps, brush, roots, boulders and like material and all trees not intended for preservation, if deemed necessary by the Planning Board.
4. All loam and other yielding materials shall be removed from the roadway and shoulder area of each street or way and replaced with suitable material.
5. Shoulders of three (3) feet in width shall be constructed on each side of the roadway and three (3) inches in height above the gutter line. Shoulders five (5) feet in width shall be constructed where substantial fills are made and highway guard is required or where sidewalks are installed. Shoulders shall be loomed and seeded.
6. All roads shall have two (2) six (6)-inch courses of gravel and two (2) courses of Class I bituminous concrete Type 1-2. The first course of gravel shall be six (6) inches thick and contain no stones greater than six (6) inches in diameter. The second course of gravel shall be six (6) inches of binding gravel containing no stones larger than two (2) inches in diameter. Each course shall be compacted by being rolled by a 10-ton roller or equivalent machinery. The final course of gravel shall be properly graded by an approved grader and brought to the true line and grade as shown on the typical section in Appendix 5 and approved profiles.
7. As an alternative to 12" of gravel, a base material consisting of reclaimed asphalt meeting the requirements of the Massachusetts Standard Specifications Section M 1.11.0 may be substituted. The minimum thickness of this material shall be eight (8) inches.
8. The first course of bituminous concrete shall consist of 2 [two] inches of binder and the second course shall consist of 1-1/2 inches of top-wearing surface. The dates for placing bituminous concrete shall be the dates before November 15<sup>th</sup> and after May 15<sup>th</sup> or as authorized by the Town Engineer or Board's Consulting Engineer.
9. Street sections are shown in the Appendices.

**D. Street Lights**

Street lights shall be installed at each intersection to conform to the standard established by the Town and the Director of Municipal Maintenance, and may be required at such other intervals as specified by the Board. Driveway entrance lights may be substituted for standard street lights.

**E. Street Signs**

1. The developer shall furnish and erect necessary street signs at each intersection to designate the name of each street in the development.
2. Signs shall conform to those used by the Town with Planning Board approval.

**F. Street Trees**

Street trees not less than 12 feet in height and of a species approved by the Tree Warden or Director of Municipal Maintenance shall be planted on each side of every street in the subdivision wherever, in the opinion of the Planning Board, existing woodlands or suitable individual trees are not retained in sufficient quantity or depth. New trees shall not be located between the sidewalk and curb or gutter line of the adjacent pavement.

**G. Sidewalks**

Sidewalks of not less than five (5) feet in width shall be constructed on at least one (1) side of Residential Minor and Residential Local Streets and on both/two sides of Residential Standard and Residential Collector Streets.

For all non-residential subdivisions, the sidewalks will be determined by the Planning Board at the time of submission.

Sidewalks shall be separated from the roadway edge by a border of no less than three (3) feet on Residential Minor and Residential Local Streets and five [5] feet on Residential Standard and Residential Collector Streets to increase pedestrian safety. Sidewalk width shall be increased and pedestrian ramps constructed to provide access for the elderly or handicapped when, in the opinion of the Planning Board, the volume or nature of pedestrian traffic justify such installation.

Sidewalks shall be constructed in conformance with the specifications of the Director of Municipal Maintenance and the Town Engineer (See Appendix 6).

**H. Curbs**

Curbs of pre-cast concrete, extruded reinforced cement concrete, granite or Cape Cod Berm shall be constructed on both sides of the street regardless of street grade in accordance with these Rules & Regulations.

**I. Monuments**

Monuments shall be installed at all street intersections, at all points of change in direction or curvature of streets and all other points where, in the opinion of the Planning Board, permanent monuments are necessary. Such monuments shall conform to the standard specifications of the Town Engineer and shall be set according to such specifications. The monuments shall be 5" x 5" x 36" steel reinforced concrete.

**J. Brush and Slash**

All brush and slash must be removed from the borders of streets in conformance with the Fire Safety Officer's recommendations.

**K. Fire Alarms**

Fire alarm systems shall be constructed in accordance with the requirements of the Wareham Fire District or the Onset Fire District. Fire alarm boxes are no longer considered necessary.

**L. Grounds**

In subdivisions involving multiple dwellings or apartments, the construction of driveways, parking areas, recreation areas and landscaping of grounds shall be completed in a manner satisfactory to the Planning Board before applying for occupancy permits. Satisfactory shall mean partial to fully screened development, shading for energy efficiency, and ability to hide utilities.

**Section VII – Filing Fees**

**A. Approval Not Required Plans**

\$150.00 per plan sheet plus \$50.00 for each newly-created lot.

**B. Preliminary Plan**

\$500.00 plus \$100.00 per lot  
\$100 advertising

**C. Definitive Plan**

\$750.00 plus \$75 per lot plus \$1.000 per linear foot of roadway if a Preliminary Plan was submitted.  
\$100 advertising

\$1,500 plus \$50 per lot plus \$1.00 per linear foot of roadway if a Preliminary Plan was not submitted.  
\$100 advertising

**D. Covenant Release**

\$100.00 per request if release involves posting of other security for incomplete roads.

No charge if road system is complete and satisfactory report filed of final construction inspection.

**E. Review Fees**

Where specific conditions arising from the land or the nature of the proposal necessitates the assistance of planning, engineering, legal, traffic, soil, hydrologic or other consultants, the Planning Board may engage such consultant services to assist the Board in analyzing the project to ensure compliance with all relevant laws, by-laws, regulations, best management practices and good design principles. In these instances, the Planning Board will require the applicant to pay a review fee consisting of the reasonable costs to be incurred by the Board for these services. The provisions for this language are contained in M.G.L. Chapter 44, §53G and were adopted at the October 21, 2002 Town Meeting.

Funds received by the Board pursuant to this section shall be deposited with the Town Treasurer, who shall establish a special individual account for this purpose. Expenditures from this special account may be made at the direction of the Board. Expenditures from this account shall be made only in connection with the review of a specific project or projects for which a review fee has been or will be collected from the applicant. Failure by an applicant to pay all review fees shall be grounds for denial of the application or permit.

Review fees may only be spent for services rendered in connection with the specific project for which they were collected. At the completion of the Planning Board's review of a project, any excess amount of funds remaining in the account attributable to that project, including any interest accrued, shall be repaid to the applicant(s) or the applicant's successor(s). The applicant must submit a written request for these funds. Upon request, a final report for said account shall be made available to the applicant(s) or the applicant's successor(s) in interest. For the purpose of this regulation, any person or entity claiming to be an applicant's successor in interest shall provide the Board with the proper documentation establishing such succession in interest.

Any applicant may take an administrative appeal from the selection of the outside consultant to the Select Board, provided that such appeal is taken within 14 days of notification of the Planning Board's appointment of the consultant. The grounds for such an appeal shall be limited to the claim(s) that the selected consultant has a conflict of interest or does not possess the minimum required qualifications as may be set by the Planning Board. The minimum qualifications shall consist of a licensed professional in a related field. The required time limit for action upon an application by the Planning Board shall be extended by the duration of the administrative appeal.



In the event that no decision is made by the Select Board within 30 days following the filing of the appeal, the selection made by the Planning Board shall stand.

**F. Construction Observation / Inspection Fee**

The Town's Engineer or Board's Consulting Engineer shall observe and inspect the construction of required underground infrastructure and required public improvements that are not within the purview of the Building Inspector. The applicant shall pay a construction observation / inspection fee prior to the issuance of a building permit. This fee shall not be a fixed amount and will vary with the costs incurred. This fee shall be the reasonable costs to be incurred to observe and inspect the construction of the proposed improvements and shall be based on an estimate provided by the Town's Consulting Engineer. Failure by the applicant to pay the appropriate fee for construction observation / inspection services will result in the applicant's inability to attain any building permits or schedule required inspections. Failure to pay these fees within 30 days of the filing of the Definitive Plan (Form C) decision may result in the rescission of the Definitive Plan approval by the Planning Board.

**G. Other Costs and Expenses**

All expenses for professional services, ancillary report reviews, supplemental studies, advertising, publication of notices, postage and mailings and all other expenses in connection to the proposed subdivision including without limitation sampling and/or testing, shall be borne by the applicant. Re-inspection fees shall be the reasonable costs to be incurred to observe and inspect the construction of the proposed improvements and shall be based on an estimate provided by the Town's Engineer.

**Section VIII – Forms and Documents**

- Form A: Application for Endorsement of Plan Believed Not to Require Approval
- Form B: Application for Approval of Preliminary Plan
- Form C: Application for Approval of Definitive Plan
- Form F: Covenant
- Form N: Control Form for Processing Road Construction and Inspections

DRAFT Certificate of Approval

**Appendices**

Form A

APPLICATION FOR ENDORSEMENT OF PLAN  
BELIEVED NOT TO REQUIRE APPROVAL

\_\_\_\_\_, 20\_\_\_\_

To the Planning Board of the Town of Wareham

The undersigned wishes to record the accompanying plan and requests a determination and endorsement by said Board that approval by it under the Subdivision Control Law is not required. The undersigned believes that such approval is not required for the following reasons: (Circle as appropriate.)

1. The accompanying plan is not a subdivision because the plan does not show a division of land.
2. The division of the tract of land shown on the accompanying plan is not a subdivision because every lot shown on the plan has frontage of at least such distance as is presently required by the \_\_\_\_\_ zoning by-law/ordinance under Section \_\_\_\_\_ which requires \_\_\_\_\_ feet for erection of a building on such lot; and every lot shown on the plan has such frontage on:
  - a. a public way or way which the City or Town Clerk certifies is maintained and used as a public way, namely \_\_\_\_\_, or
  - b. a way shown on a plan theretofore approved and endorsed in accordance with the subdivision control law, namely \_\_\_\_\_ on \_\_\_\_\_, and subject to the following conditions \_\_\_\_\_; or
  - c. a private way in existence on \_\_\_\_\_, the date when the subdivision control law became effective in the city/town of \_\_\_\_\_ having, in the opinion of the Planning Board, sufficient width, suitable grades, and adequate construction to provide for the needs of vehicular traffic in relation to the proposed use of the land abutting thereon or served thereby, and for the installation of municipal services to serve such land and the buildings erected or to be erected thereon, namely \_\_\_\_\_
3. The division of the tract of land shown on the accompanying plan is not a “subdivision” because it shows a proposed conveyance/other instrument, namely \_\_\_\_\_ which adds to/takes away from/changes the size and shape of, lots in such a manner so that no lot affected is left without frontage as required by the \_\_\_\_\_ zoning bylaw/ordinance under Section \_\_\_\_\_, which requires \_\_\_\_\_ feet.
4. The division of the tract of land shown on the accompanying plan is not a subdivision because two or more buildings, specifically \_\_\_\_\_ buildings were standing on the plan prior to \_\_\_\_\_ the date when the subdivision control law went into effect in the town of Wareham

5. \_\_\_\_\_ and one of such buildings remains standing on each of the lots/said buildings as shown and located on the accompanying plan. Evidence of the existence of such buildings prior to the effective date of the subdivision control law is submitted as follows:

\_\_\_\_\_  
\_\_\_\_\_  
\_\_\_\_\_  
\_\_\_\_\_

APPLICANTS NAME · PLEASE PRINT

6. Other reasons or comment: (See M.G.L., Chapter 41, Section 81-L)

\_\_\_\_\_  
\_\_\_\_\_  
\_\_\_\_\_  
\_\_\_\_\_

The owner's title to the land is derived under deed from \_\_\_\_\_, dated \_\_\_\_\_ and recorded in \_\_\_\_\_ Registry of Deeds, Book \_\_\_\_\_, Page \_\_\_\_\_ and \_\_\_\_\_ Assessors Book \_\_\_\_\_, Page \_\_\_\_\_.

Received by Wareham Town Clerk:  
Date \_\_\_\_\_  
Time \_\_\_\_\_  
Signature \_\_\_\_\_

Applicant's signature \_\_\_\_\_  
Applicant' address \_\_\_\_\_  
\_\_\_\_\_  
Applicant's phone # \_\_\_\_\_  
Owner's signature and address if not the applicant or applicant's authorization if not the owner

Treasurers' office: \_\_\_\_\_  
Date: \_\_\_\_\_

\_\_\_\_\_  
\_\_\_\_\_  
\_\_\_\_\_

FORM A/ANR PLAN CHECKLIST

The plan shall be suitable for recording (24" x 36") in the Plymouth County Registry of Deeds (7 additional copies reduced on ledger-sized paper shall accompany the submission) and shall include at least the following:

1. \_\_\_\_\_ The title "Approval Not Required Plan drawn for **NAME OF OWNER**";
2. \_\_\_\_\_ Date, scale and North arrow;
3. \_\_\_\_\_ Zoning district, Tax Assessor's map and lot numbers, and location of any zoning district boundaries that may be within the locus of the plan (Approval Not Required (ANR) compliance is not indicative of zoning compliance);
4. \_\_\_\_\_ Any existing structures/septic systems on the land, including setback, side and rear yard designations;
5. \_\_\_\_\_ Remaining frontage of any adjoining land in the same ownership;
6. \_\_\_\_\_ Any existing structures/septic systems on any adjoining land in the same ownership;
7. \_\_\_\_\_ Names of present landowners and names of abutters from the most recent tax list;
8. \_\_\_\_\_ Location of any easement or ways, public or private, across the land with A designation as to its purpose;
9. \_\_\_\_\_ Bearings and distance of all lines of the lots shown on the plan;
10. \_\_\_\_\_ Notice of any decision by the Zoning Board of Appeals, including but not limited to variances and exceptions in regard to the land or any buildings thereon;
11. \_\_\_\_\_ A block with the statement "Approval Under the Subdivision Control Law Not Required" with sufficient space for the date and signatures of all Board members;
12. \_\_\_\_\_ A locus scale of 1" = 2,000' sufficient to identify the location of the property;
13. \_\_\_\_\_ The name, seal and signature of the Registered Professional Land Surveyor who prepared the plan.

**TOWN OF WAREHAM  
ANR/SUBDIVISION/SITE PLAN REVIEW FORM**

Check one:            ANR \_\_\_\_\_ Form B \_\_\_\_\_ Form C \_\_\_\_\_ Site Plan Review \_\_\_\_\_

Date stamped in \_\_\_\_\_ Date decision is due \_\_\_\_\_

Applicant's name(s) \_\_\_\_\_

Applicant's address  
\_\_\_\_\_

Telephone number \_\_\_\_\_

Address of property \_\_\_\_\_

Landowner's name \_\_\_\_\_

Owner's address \_\_\_\_\_

Telephone number \_\_\_\_\_

Contact person \_\_\_\_\_ Telephone \_\_\_\_\_

Map # \_\_\_\_\_ Lot # \_\_\_\_\_

Zone \_\_\_\_\_

Date Approved \_\_\_\_\_ Date Denied \_\_\_\_\_

Comments (state reasons for denial or stipulations of approval)  
\_\_\_\_\_  
\_\_\_\_\_  
\_\_\_\_\_  
\_\_\_\_\_  
\_\_\_\_\_  
\_\_\_\_\_  
\_\_\_\_\_  
\_\_\_\_\_  
\_\_\_\_\_  
\_\_\_\_\_

Conditions for: \_\_\_\_\_  
\_\_\_\_\_  
\_\_\_\_\_  
\_\_\_\_\_  
\_\_\_\_\_  
\_\_\_\_\_  
\_\_\_\_\_

**RECORD OF PLANNING BOARD PROCEEDINGS AND DECISIONS**  
**Town of Wareham Planning Board**

Name of Subdivision or Project:

\_\_\_\_\_

\_\_\_\_\_

APPLICATION: FORM A \_\_\_\_\_ FORM B \_\_\_\_\_ FORM C \_\_\_\_\_

OTHER \_\_\_\_\_

DATE SUBMITTED:

\_\_\_\_\_

DATE DECISION IS DUE:

\_\_\_\_\_

DATE OF PUBLIC HEARING(S):

\_\_\_\_\_

DECISION DATE:

\_\_\_\_\_

DATE DECISION SENT TO TOWN CLERK:

\_\_\_\_\_

DATE APPEALS PERIOD BEGINS \_\_\_\_\_ ENDS \_\_\_\_\_

PLANNING BOARD DECISIONS: (yes or no or abstention) if abstaining, appropriate recusal form should accompany decision.

FORM A:      FORM B:      FORM C:

C.Schulz \_\_\_\_\_ M. Baptiste \_\_\_\_\_ M. King \_\_\_\_\_ J. Gleason \_\_\_\_\_  
S. Corbitt \_\_\_\_\_ S. Quirk [Alternate] \_\_\_\_\_

**Standard Conditions:**

- Construction shall substantially conform to the approved Site Development Plan dated (ENTER DATE OF PLAN WITH ANY REVISION DATES) except as modified by the below listed conditions.
- If substantial use or construction permitted by this approval has not commenced within two years from the date on which a copy of this decision was filed with the Town Clerk, excluding the amount of time required for the appeal period of twenty days to expire and the amount of time to pursue and await the final determination of any such appeal, then this approval shall expire.

- The developer/applicant shall be required to establish a Homeowners Association (HOA) that will be responsible for the maintenance and operation of the approved street light plan and to provide for the maintenance and operation the storm water system including any and all retention basins, and all other common land within the approved subdivision. The HOA organization will be approved by Town Counsel and shall remain in force and operation for the duration of the life of the subdivision.
- The developer/applicant shall develop a storm water management and maintenance plan as required by the Rules and Regulations Governing the Subdivision of Land. Such plan shall be approved by the Town's Conservation Administration and Wareham's Director of Municipal Maintenance prior to the start of construction. The plan will prevent runoff of storm water to abutting properties. The developer/applicant's general contractor will be responsible for the inspection and maintenance of the storm water BMP during construction, including the submission of required reports to the Planning Board and Conservation Administrator. Once the construction is complete and the complex has been accepted, the HOA will be responsible for the required inspections and maintenance of the storm water system as delineated on the approved plan.
- With the final approval of the Site Development Plan the developer/applicant shall work with the Town Engineer and Director of Municipal Maintenance to compile a list of inspections required under Form N, Town of Wareham's Rules and Regulations Governing the Subdivision of Land.
- All rubbish, rubble, metals, stumps, and other debris shall be removed and properly disposed off-site. The developer/applicant will provide a "port-a-potty" on site for the use of construction crews. No work will be permitted on Sundays and legal holidays unless specific approval is granted by the Town of Wareham's Zoning Enforcement Officer.
- The site will not be clear-cut. The applicant shall preserve a minimum of 10' vegetative buffer along the side and rear lot lines of all lots. The developer/applicant will provide a landscaping plan under Article X of the Town of Wareham Zoning Bylaws that will indicate existing vegetation, including trees, which will be preserved. To ensure the long term maintenance and implementation a two year guarantee program shall be provided to the Town on all new plant material. Street trees shall be planted along every 50' along both sides of the road. The developer/applicant furnished landscape material for street use shall be drought resistant.
- Street lighting is required by the Town of Wareham's Rules and Regulations Governing the Subdivision of Land, is required to maintain all streets and utilities in satisfactory condition until such streets and utilities are accepted by the Town of Wareham.
- Be advised that the developer/applicant, under Section (1)c of the Town of Wareham Rules and Regulations Governing the Subdivision of Land, is required to maintain all streets and utilities in satisfactory condition until such streets and utilities are accepted by the Town of Wareham.
- If public water is available within 1,500' the applicant shall be required to connect to the system per Section VI, part B.4 of the Town of Wareham Rules and Regulations Governing the Subdivision of Land.

- No further subdivision of any lots by this action, to create any new buildable lots, will be permitted in perpetuity.
- Approvals and conditions from all other applicable Town Departments, Town Boards, Town Commissions and State agencies shall be made part of these conditions.

Other Conditions:

---

---

---

---

---

---

Signature: \_\_\_\_\_  
Chairman

Received by Town Clerk:

Date \_\_\_\_\_

Time \_\_\_\_\_

Signature \_\_\_\_\_



**Town of Wareham  
Street Name Application Form**

Application Date: \_\_\_\_\_

**Applicant:**

- Check with Planning Board or Board of Selectmen to determine availability of street names.
- One copy of this form, filled out and signed should be submitted with a completed application for Form B, or Form C.
- Note: Use this form for any new street name requests for public OR private ways.

**To the Planning Board:**

The undersigned applicant requests the Board's approval of the following proposed names of street(s) within the proposed subdivision shown on a plan entitled: \_\_\_\_\_ and dated \_\_\_\_\_.

**Proposed Street name(s):**

**Alternative name(s)**

|  |  |
|--|--|
|  |  |
|  |  |
|  |  |
|  |  |

Applicant's Signature: \_\_\_\_\_  
Address: \_\_\_\_\_

The Planning Board requests your comments on this application for approval of the above proposed street name(s):

\_\_\_\_\_

\_\_\_\_\_

Please submit your comments to the Planning Board before: \_\_\_\_\_

**Approved Name(s):** \_\_\_\_\_

**Approval Date:** \_\_\_\_\_

\_\_\_\_\_

\_\_\_\_\_

**Planning Board Signatures:**

|  |  |
|--|--|
|  |  |
|  |  |
|  |  |

**Distribution List:**

- |                       |                               |                   |
|-----------------------|-------------------------------|-------------------|
| Board of Selectmen    | Building Department           | EMS               |
| Police Department     | Board of Health               | Fire Department   |
| Community Development | Wareham Historical Commission | Assessor's Office |
| Municipal Maintenance | Water Department              |                   |

**PLANNING BOARD**  
**TAX VERIFICATION FORM**

This verifies that \_\_\_\_\_ (name of applicant) is up-to-date on the taxes for the property(ies) he/she owns in Wareham. If the applicant is not the current owner of the property that the application addresses, the current owner \_\_\_\_\_ (name of property owner) is up-to-date on taxes and on all properties he/she owns in the Town of Wareham.

\_\_\_\_\_  
John Foster, Tax Collector

Form B

Town of Wareham  
APPLICATION FOR APPROVAL OF A PRELIMINARY PLAN

\_\_\_\_\_, 20\_\_\_\_

To the Planning Board of the Town of Wareham

The undersigned, being the applicant as defined under the Chapter 41, Section 81-L, for approval of a proposed subdivision shown on a plan entitled:

\_\_\_\_\_

by \_\_\_\_\_, dated \_\_\_\_\_ and described as follows: located at \_\_\_\_\_, number of lots proposed \_\_\_\_\_ total acreage of tract \_\_\_\_\_, said applicant hereby submits said plan as a *Preliminary* subdivision plan in accordance with the Rules and Regulations of the Wareham Planning Board and makes application to the Board for approval of said plan.

The undersigned's title to said land is derived from \_\_\_\_\_

by deed dated \_\_\_\_\_ and recorded in the

Plymouth County District Registry of Deeds Book \_\_\_\_\_, Page \_\_\_\_\_, registered in the Registry District of the Land Court. Certificate of Title No. \_\_\_\_\_

Received by Town Clerk:

Applicant's signature \_\_\_\_\_

Applicant' address \_\_\_\_\_

Date \_\_\_\_\_

Time \_\_\_\_\_

Applicant's phone # \_\_\_\_\_

Signature \_\_\_\_\_

Owner's signature and address if not the applicant or applicant's authorization if not the owner

Received by Board of Health:

Date \_\_\_\_\_

Time \_\_\_\_\_

Signature \_\_\_\_\_

FORM B/PRELIMINARY PLAN CHECKLIST

The Preliminary Plan shall be drawn on appropriate, reducible paper and should exhibit the following information by which to form a clear basis for discussion and for the preparation of a Definitive Plan:

- 14. \_\_\_\_\_ The title, “Preliminary Plan of (name of subdivision)”;
- 15. \_\_\_\_\_ Date, scale and North arrow, Assessor’s Map(s) and Lot(s) number(s) and a legend to explain any graphic representation or symbols on the plan;
- 16. \_\_\_\_\_ The names, addresses and telephone numbers of the owner(s) of record and applicant(s);
- 17. \_\_\_\_\_ The names of the designer, engineer and/or surveyor who prepared the plan;
- 18. \_\_\_\_\_ The names of all abutters, as determined from the most recent local tax list;
- 19. \_\_\_\_\_ The existing and proposed lines of streets, ways, easements and any public areas within the subdivision;
- 20. \_\_\_\_\_ The proposed drainage system, including adjacent existing natural waterways;
- 21. \_\_\_\_\_ The approximate boundary lines, dimensions, and areas of proposed lots;
- 22. \_\_\_\_\_ The names, locations, and widths of adjacent streets;
- 23. \_\_\_\_\_ The general topography of the land;
- 24. \_\_\_\_\_ Location and distance to nearest public water and sewer utility services;
- 25. \_\_\_\_\_ A locus map scaled at 1” = 2,000’ and an aerial map exhibiting the general area surrounding the subject property (approximately ½ mile surrounding the site).

This application constitutes the applicant’s willingness to work under the Town of Wareham’s Subdivision Rules and Regulations. Any errors or omissions from this checklist or the Subdivision Regulations may result in the applicant not being place on a Planning Board agenda or denial of this Form B/Preliminary Plan.

**FORM F**  
**COVENANT**

Town of Wareham, Massachusetts

KNOW ALL MEN by these presents that the undersigned has submitted an application dated \_\_\_\_\_, to the \_\_\_\_\_  
Planning Board for approval of a Definitive Plan of a subdivision of land entitled \_\_\_\_\_

plan by: \_\_\_\_\_, dated: \_\_\_\_\_  
revised: \_\_\_\_\_

and owned by: \_\_\_\_\_

address: \_\_\_\_\_

land located: \_\_\_\_\_

and showing: \_\_\_\_\_ proposed residential lots and \_\_\_\_\_ open space lots. The undersigned has requested the Planning Board to approve such plan without requiring a performance bond.

IN CONSIDERATION of said Planning Board of Wareham in the County of Plymouth approving said plan without requiring a performance bond, the undersigned hereby covenants and agrees with the Inhabitants of the Town of Wareham as follows:

1. That the undersigned is the owner in a fee simple absolute of all the land included in the subdivision and that there are no mortgages of record or otherwise of any of the land.
2. That the undersigned will not sell or convey any lot in the subdivision or erect or place any permanent building on any lot until the construction of ways and installation of municipal services necessary to adequately serve such lot has been completed in accordance with the covenants, conditions, agreements, terms and provisions as specified in the following:
  - a. The Application for Approval of Definitive Plan (Form C).
  - b. The Subdivision Control Law and the Planning Board's Rules and Regulations governing this subdivision.
  - c. The Certificate of Approval and the conditions of approval specified herein, issued by the Planning Board, dated \_\_\_\_\_.
  - d. The Definitive Plan as approved and as qualified by the Certificate of Approval.
  - e. Other document(s) specifying construction to be completed, namely:  
\_\_\_\_\_  
\_\_\_\_\_  
\_\_\_\_\_

3. This covenant shall be binding upon the executors, administrators, devisees, heirs, successors and assigns of the undersigned and shall operate as restrictions upon the land.
4. That particular lots within the subdivision shall be released from the foregoing by the Planning Board and enumerating the specific lots to be released.
5. That nothing herein shall be deemed to prohibit a conveyance by a single deed subject to this covenant, of either the entire parcel of land shown on the subdivision plan or of all lots not previously released by the Planning Board.
6. That the undersigned agrees to record this covenant with the Plymouth County Registry of Deeds forthwith, or to pay the necessary recording fee to the said Planning Board in the event the Planning Board shall record this agreement. Reference to this covenant shall be entered upon the Definitive Subdivision Plan as approved.
7. A deed of any part of the subdivision in violation of the covenant shall be voidable by the grantee prior to the release of the covenant, but not later than three (3) years from the date of such deed as provided in Section 81-U, Chapter 41, M.G.L.
8. That this covenant shall be executed before endorsement of approval of the Definitive Plan by the Planning Board and shall take effect upon the endorsement of the approval.
9. Upon final completion of the construction of ways and installation of municipal services as specified herein, on or before \_\_\_\_\_ the Planning Board shall release this covenant by an appropriate instrument, duly acknowledged. Failure to complete construction and installation within the time specified herein or such later date as may be specified by vote of the Planning Board with a written occurrence of the applicant shall result in automatic rescission of the approval of the plan. Upon performance of this covenant with respect to any lot, the Planning Board may release such lot from this covenant by an appropriate instrument duly recorded.
10. Nothing herein shall prohibit the applicant from varying the method of securing the construction of ways and installation of municipal services from time to time or from securing by one, or in part by one and in part by another, of the methods described in M.G.L. Chapter 41, Section 81-U, as long as such security is sufficient in the opinion of the Planning Board to secure performance of the construction and installation.

For title to the property, see deeds recorded in Plymouth County Registry of Deeds, Book \_\_\_\_\_, Page \_\_\_\_\_, or registered in \_\_\_\_\_ Land Registry as Document No. \_\_\_\_\_, and noted on Certificate of Title No. \_\_\_\_\_ in Registration Book \_\_\_\_\_, Page \_\_\_\_\_.

The present holder of a mortgage upon the property is \_\_\_\_\_ of \_\_\_\_\_ . The mortgage is dated \_\_\_\_\_ and recorded in Plymouth County Land Registry as Document No. \_\_\_\_\_ and noted on Certificate of Title No. \_\_\_\_\_ in Registration Book \_\_\_\_\_, Page \_\_\_\_\_.

\_\_\_\_\_. The mortgagee agrees to hold the mortgage subject to the covenants set forth above and agrees that the covenants shall have the same status, force and effect as though executed and recorded before the taking of the mortgage and further agrees that the mortgage shall be subordinate to the above covenant.

\_\_\_\_\_ spouse of the undersigned applicant hereby agrees that such interest as I, we, may have in the premises shall be subject to the provisions of this covenant and insofar as is necessary releases all rights of tenancy by the dower or homestead and other interests therein.

IN WITNESS WHEREOF we have hereunto set our hands and seals this \_\_\_\_\_ of \_\_\_\_\_, 20\_\_\_\_\_.

OWNER:

By: \_\_\_\_\_  
\_\_\_\_\_  
\_\_\_\_\_  
\_\_\_\_\_  
\_\_\_\_\_

Acceptance by a Majority of the Planning Board of Wareham

One Acknowledgement must be completed for each of the following:

- Planning Board representative
- Owner or owners
- Spouse of the owner
- Mortgagee

COMMONWEALTH OF MASSACHUSETTS

On this \_\_\_\_ day of \_\_\_\_\_, 20\_\_\_\_, before me, the undersigned notary public, personally appeared \_\_\_\_\_, proved to me through satisfactory evidence of identification, which was a Massachusetts Driver's License to be the person whose name is signed on the preceding or attached document, and acknowledged to me that (he)(she) signed it voluntarily for its stated purpose.

\_\_\_\_\_  
Signature of the Notary Public  
Name: \_\_\_\_\_  
My commission expires: \_\_\_\_\_

**FORM N**

**CONTROL FORM FOR PROCESSING  
SUBDIVISION PLAN AND CONSTRUCTION**

**SUBDIVISION PLAN ENTITLED:** \_\_\_\_\_

**LAND LOCATED:** \_\_\_\_\_

**BY:** \_\_\_\_\_

**APPLICANT:** \_\_\_\_\_ **ADDRESS:** \_\_\_\_\_

**PHONE:** \_\_\_\_\_

**DATE OF DEFINITIVE PLAN** \_\_\_\_\_

**INSPECTIONS**

| <b><u>DATE</u></b> | <b><u>TYPE</u></b>                    | <b><u>SIGNATURE OF INSPECTOR<br/>WHEN INSPECTION COMPLETED</u></b> |
|--------------------|---------------------------------------|--|
| 1. _____           | Clearing, grubbing<br>& Excavation    | _____  |
| 2. _____           | Drainage system                       | _____  |
| _____              | Water system                          | _____  |
| _____              | Sewer system                          | _____  |
| _____              | Underground utilities                 | _____  |
| 3. _____           | Backfill, fill, & rough<br>grading    | _____  |
| 4. _____           | Gravel base                           | _____  |
| 5. _____           | Compaction testing                    | _____  |
| 6. _____           | Bituminous Concrete                   | _____  |
| _____              | Binder Course/curbs/berms             | _____  |
| 7. _____           | Bituminous Concrete<br>Surface Course | _____  |
| 8. _____           | Sidewalks                             | _____  |
| _____              | Loam & seed                           | _____  |
| _____              | Street trees                          | _____  |
| _____              | Road signs                            | _____  |
| _____              | Street lights                         | _____  |
| _____              | Fire hydrants                         | _____  |
| _____              | Fire alarm system                     | _____  |
| _____              | Other                                 | _____  |



- 9. \_\_\_\_\_ **Bounds** \_\_\_\_\_
- 10. \_\_\_\_\_ **Final inspection** \_\_\_\_\_
- \_\_\_\_\_ **Final clean-up** \_\_\_\_\_

APPENDICES:

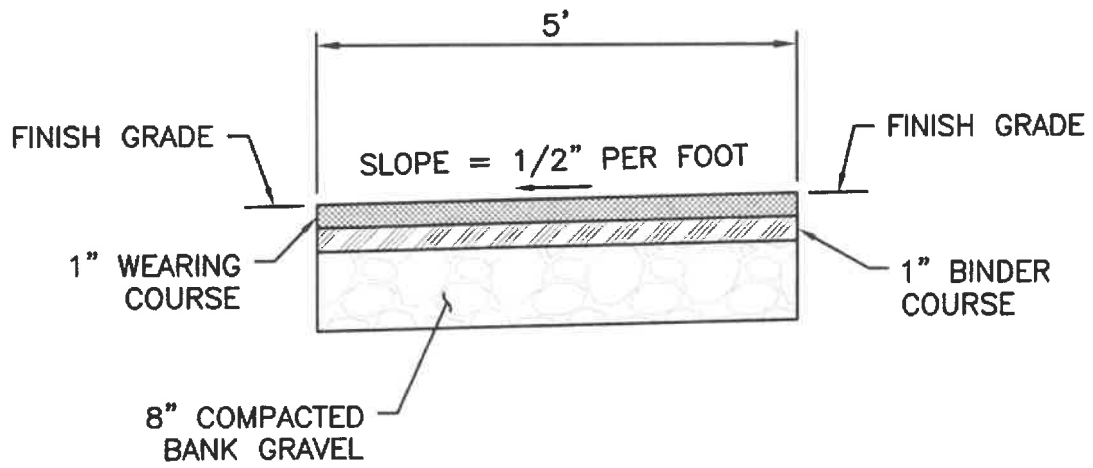

**TYPICAL BITUMINOUS CONCRETE SIDEWALK DETAIL**

**NOT TO SCALE**

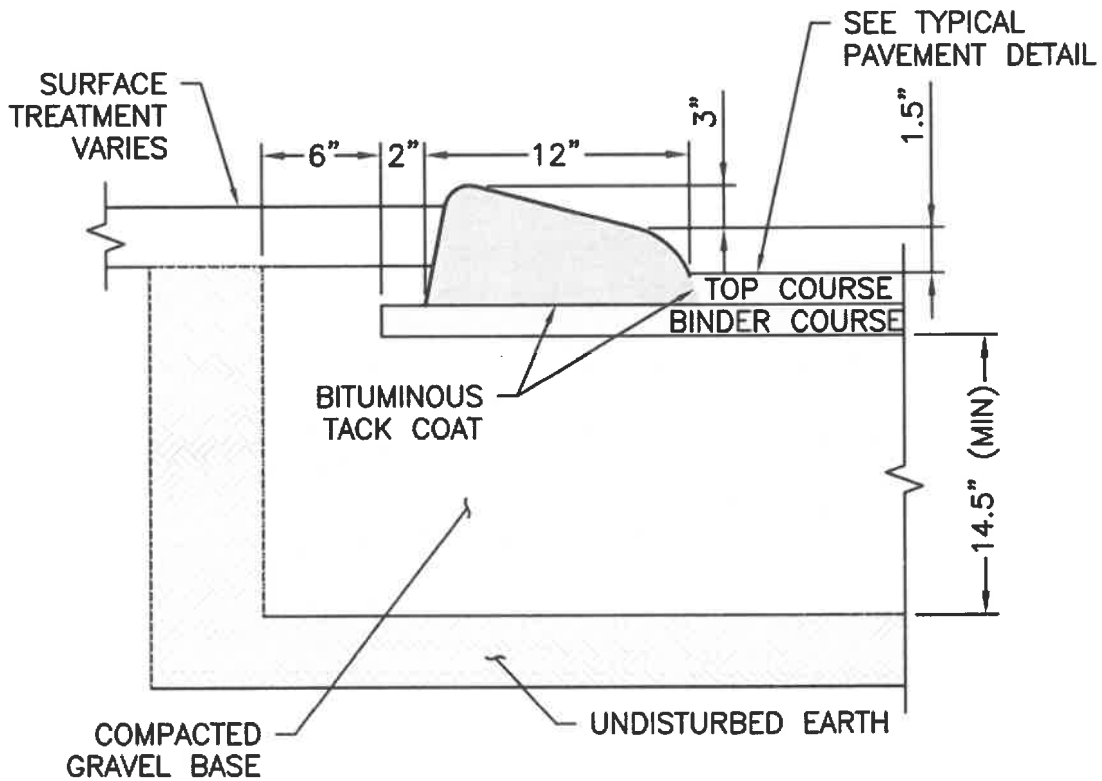

**NOTES:**

1. CURBING SHALL BE CONSTRUCTED ON BOTH SIDES OF THE STREET IN CONFORMANCE WITH THE SPECIFICATIONS OF THE DIRECTOR OF MUNICIPAL MAINTENANCE AND THE TOWN ENGINEER.
2. CAPE COD MOLDED BITUMINOUS OR BITUMINOUS BERMS SATISFACTORY TO THE PLANNING BOARD MAY BE INSTALLED WHERE, IN JUDGEMENT OF THE PLANNING BOARD, BECAUSE OF GRADES, CURVES OR TRAFFIC, THEIR INSTALLATION IS JUSTIFIED.

**CAPE COD BERM DETAIL**  
**NOT TO SCALE**

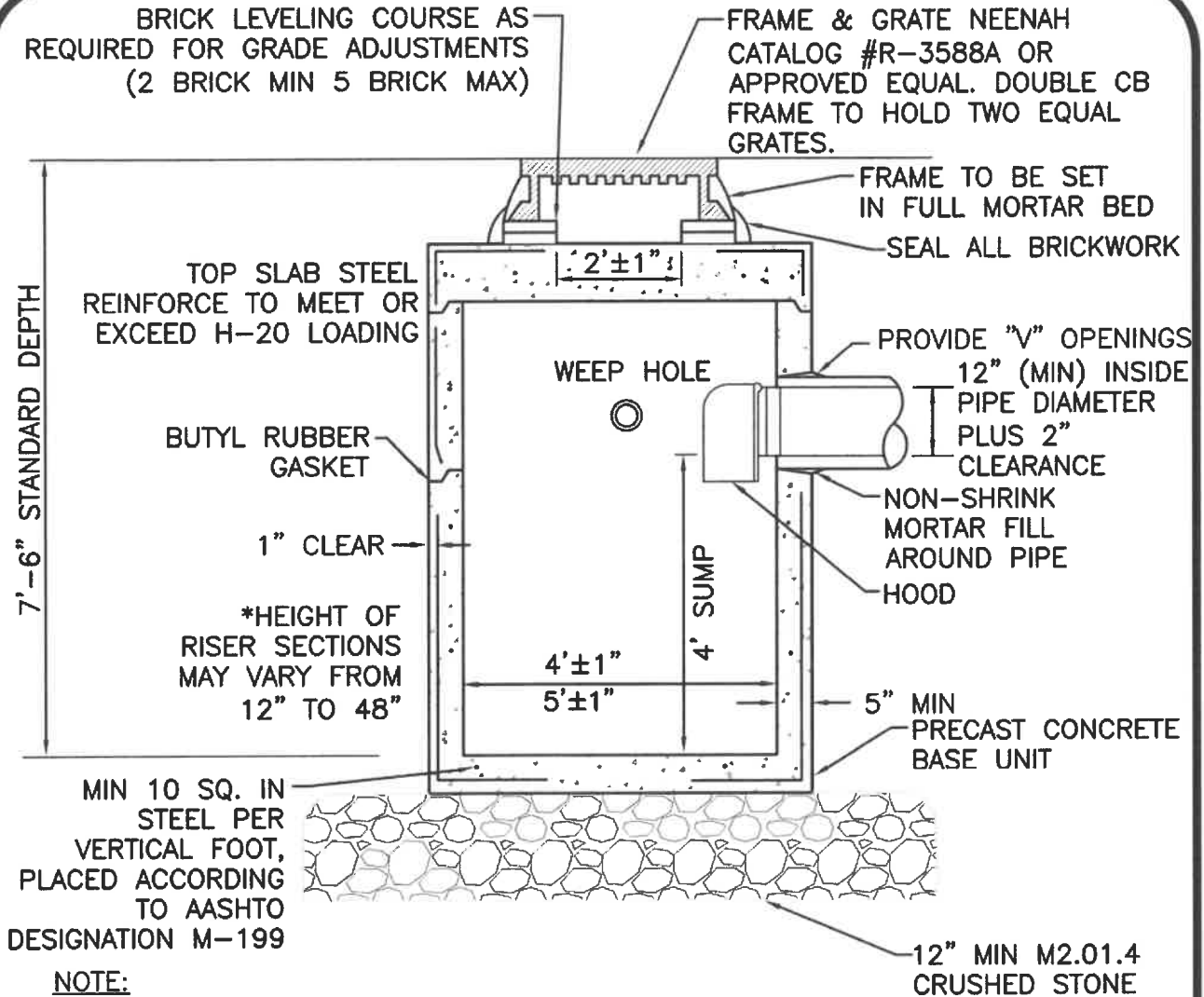

**NOTE:**

1. CATCH BASINS SHALL BE SPACED ALONG BOTH SIDES OF A STREET AT APPROXIMATELY 400-FOOT INTERVALS AND LOCATED AT ALL LOW POINTS AND CORNERS AT STREET INTERSECTIONS.

**CATCH BASIN DETAIL**

NOT TO SCALE

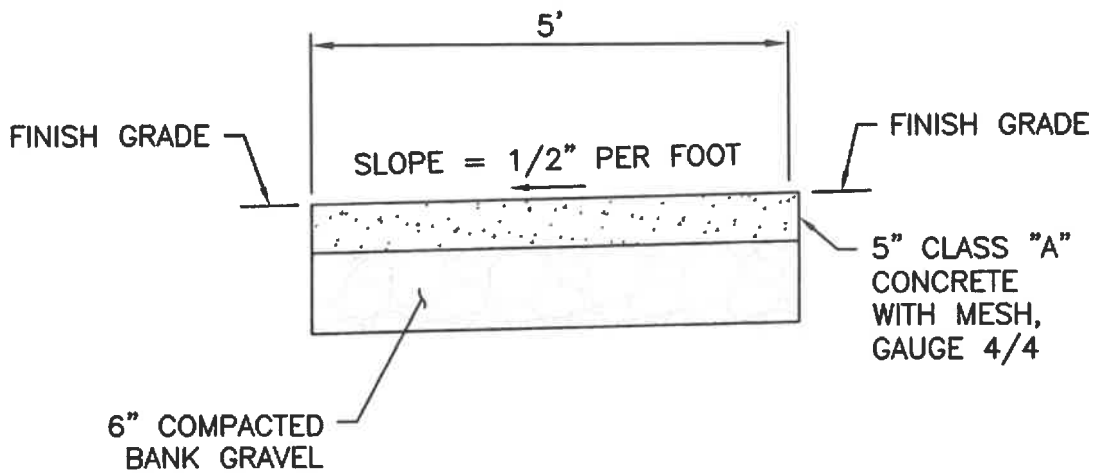

**TYPICAL CONCRETE SIDEWALK DETAIL**

**NOT TO SCALE**

FABRIC SHALL BE  
INSTALLED VERTICALLY  
DOWNSLOPE

4" (MIN)  
OVERLAP

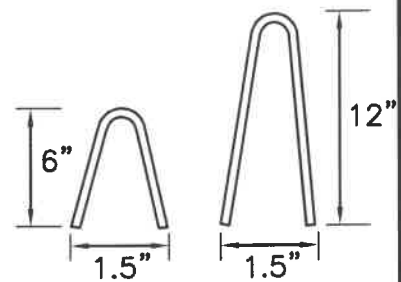
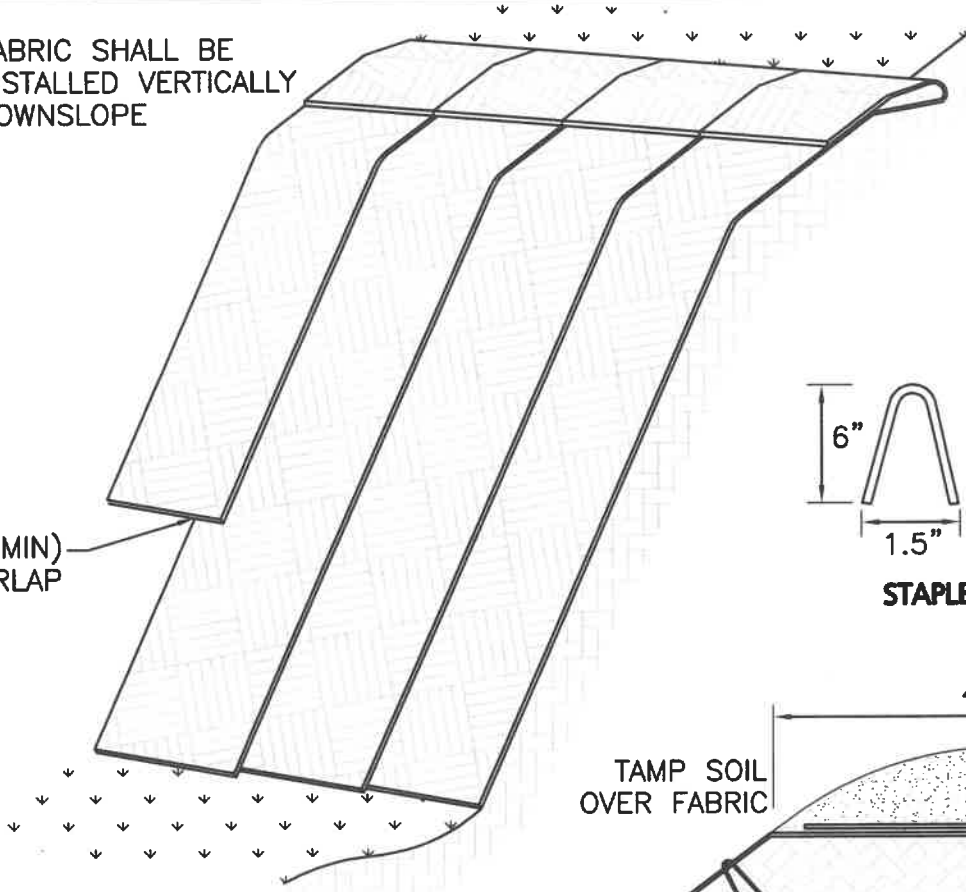

**STAPLE DETAILS**

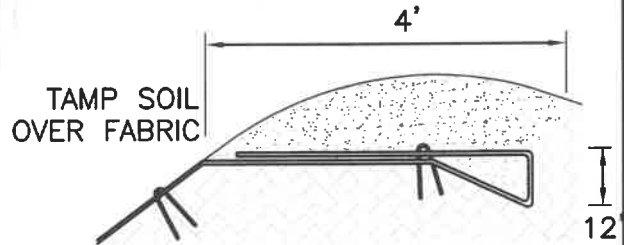

**BERM**

**NOTES:**

**ISOMETRIC VIEW**

1. SLOPE SURFACE SHALL BE FREE OF ROCKS, CLODS, STICKS AND GRASS. FABRIC SHALL HAVE GOOD SOIL CONTACT.
2. APPLY PERMANENT SEEDING BEFORE PLACING FABRIC.
3. LAY BLANKETS LOOSELY AND STAKE OR STAPLE TO MAINTAIN DIRECT CONTACT WITH THE SOIL. DO NOT STRETCH.
4. CHOOSE MATERIAL BASED ON SLOPE, SOILS, AND APPLICATION.

**EROSION CONTROL FABRIC DETAIL**

**NOT TO SCALE**

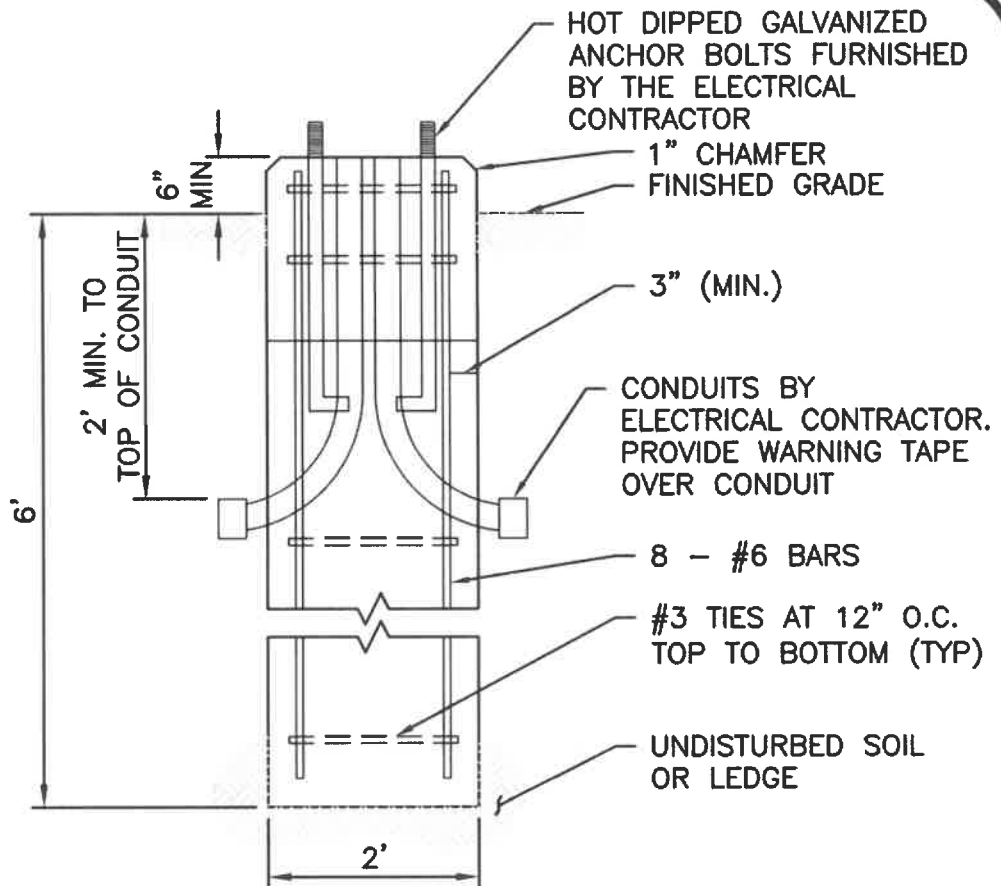

**NOTES:**

1. STREET LIGHTS SHALL BE INSTALLED AT EACH INTERSECTION TO CONFORM TO THE STANDARD ESTABLISHED BY THE TOWN AND THE DIRECTOR OF MUNICIPAL MAINTENANCE, AND MAY BE REQUIRED AT SUCH OTHER INTERVALS AS SPECIFIED BY THE BOARD.
2. ANCHOR BOLTS TO BE SET IN BOLT CIRCLE. EXACT SIZE AND LOCATION OF BOLTS MUST BE VERIFIED WITH ELECTRICAL CONTRACTOR BEFORE SETTING.

**LIGHT POLE BASE DETAIL**

**NOT TO SCALE**



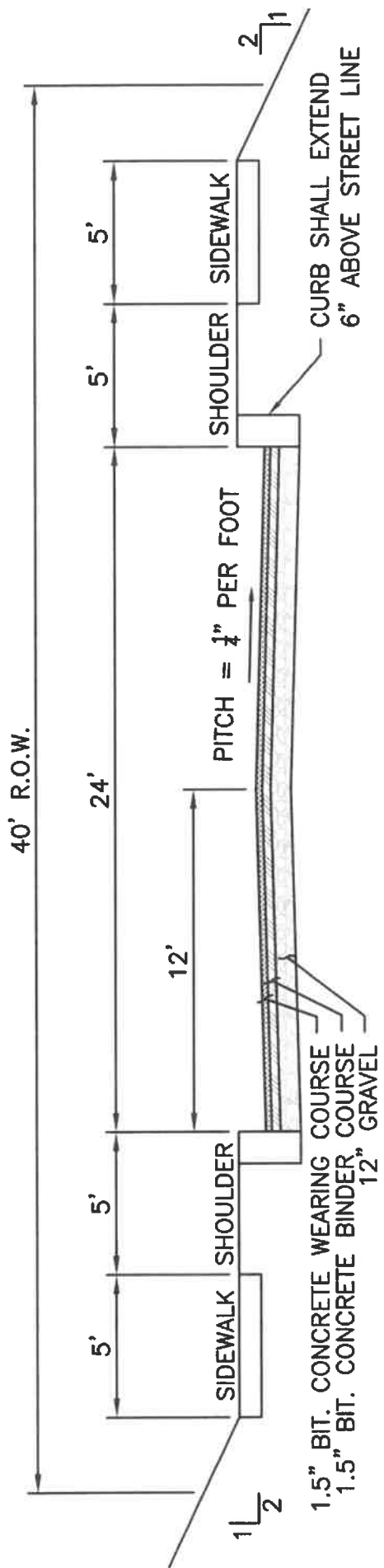

**NOTES:**

1. ALL STREETS SHALL BE DESIGNED AND CONSTRUCTED IN CONFORMANCE WITH THE TOWN OF WAREHAM SUBDIVISION RULES & REGULATIONS.

**MINIMUM ROAD DETAIL**  
 NOT TO SCALE

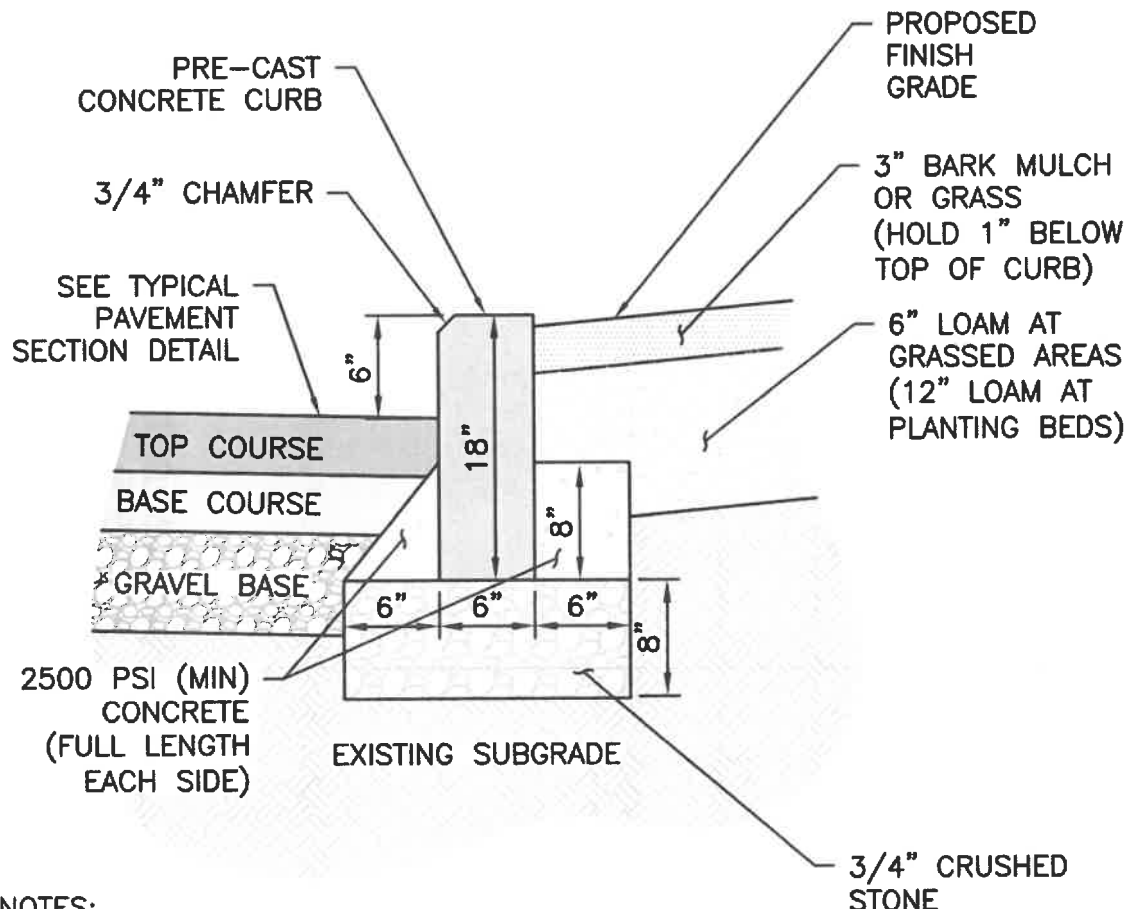

**NOTES:**

1. CURBING SHALL BE CONSTRUCTED ON BOTH SIDES OF THE STREET IN CONFORMANCE WITH THE SPECIFICATIONS OF THE DIRECTOR OF MUNICIPAL MAINTENANCE AND THE TOWN ENGINEER.

**PRE-CAST CONCRETE CURB DETAIL**

**NOT TO SCALE**

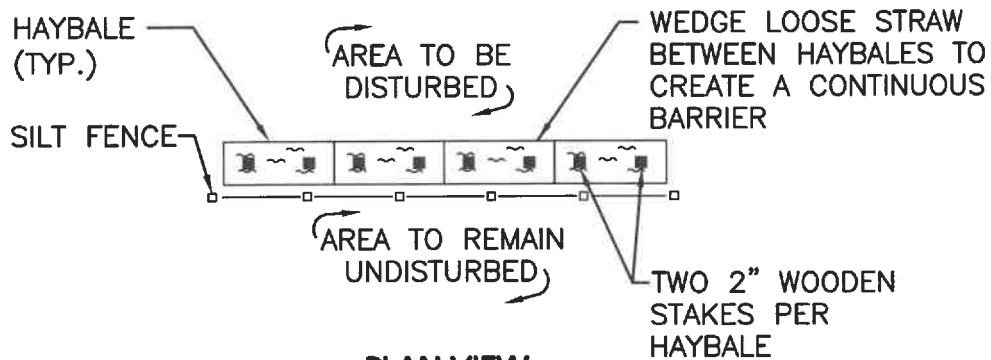

**PLAN VIEW**

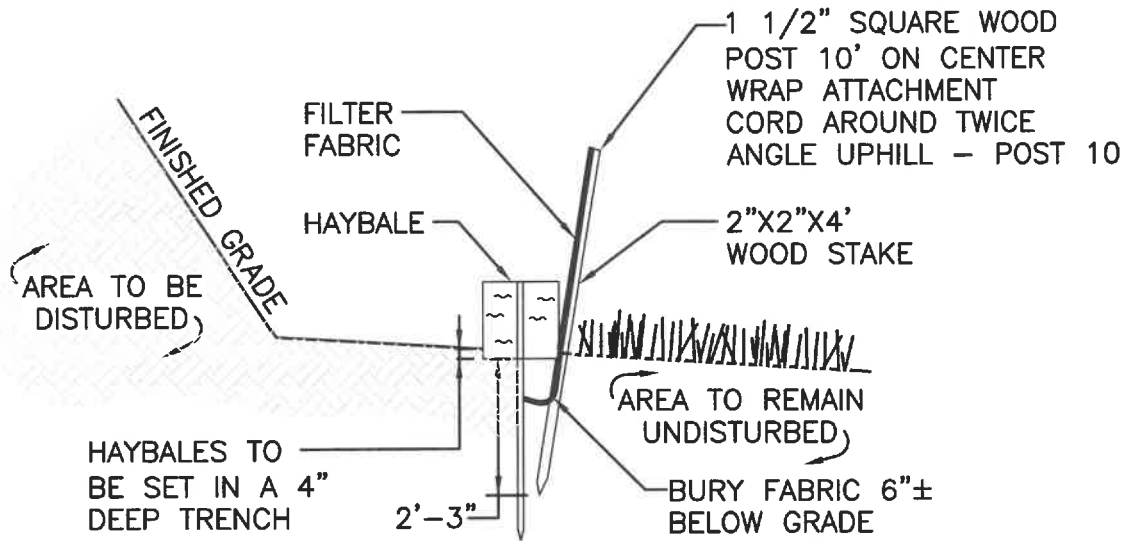

**SECTION**

NOTE:  
 DEPTH TO BE 2' UNLESS POST IS TO BE SET IN PEAT THEN 3' OR  
 DEPTH POSSIBLE BY PUSHING BY HAND SHALL BE REQUIRED.

**SILT FENCE AND HAYBALE DETAIL**

NOT TO SCALE

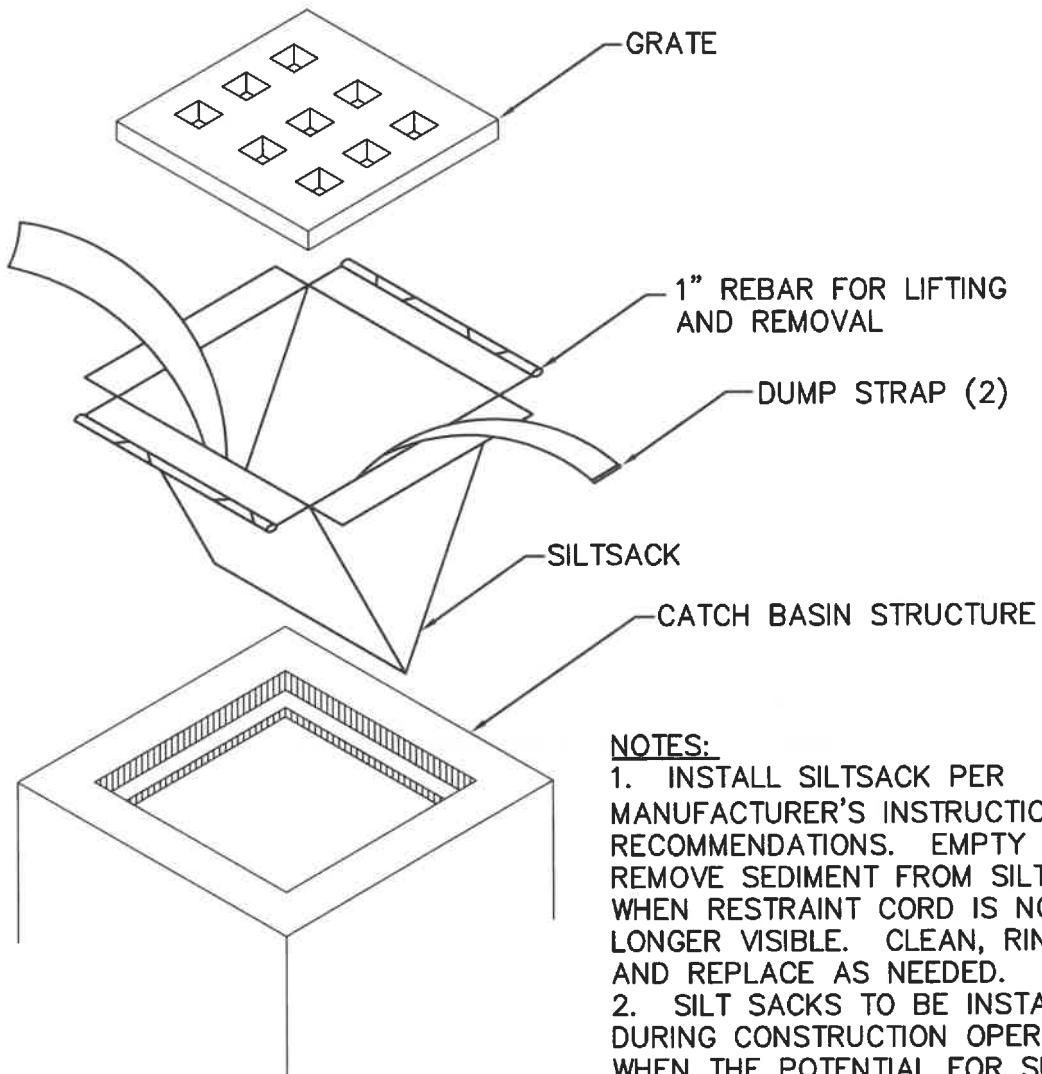

**NOTES:**

1. INSTALL SILTSACK PER MANUFACTURER'S INSTRUCTIONS AND RECOMMENDATIONS. EMPTY OR REMOVE SEDIMENT FROM SILTSACK WHEN RESTRAINT CORD IS NO LONGER VISIBLE. CLEAN, RINSE, AND REPLACE AS NEEDED.
2. SILT SACKS TO BE INSTALLED DURING CONSTRUCTION OPERATIONS WHEN THE POTENTIAL FOR SEDIMENT TO ENTER EXISTING & PROPOSED BASINS EXISTS.

**SILTSACK INLET DETAIL**

**NOT TO SCALE**

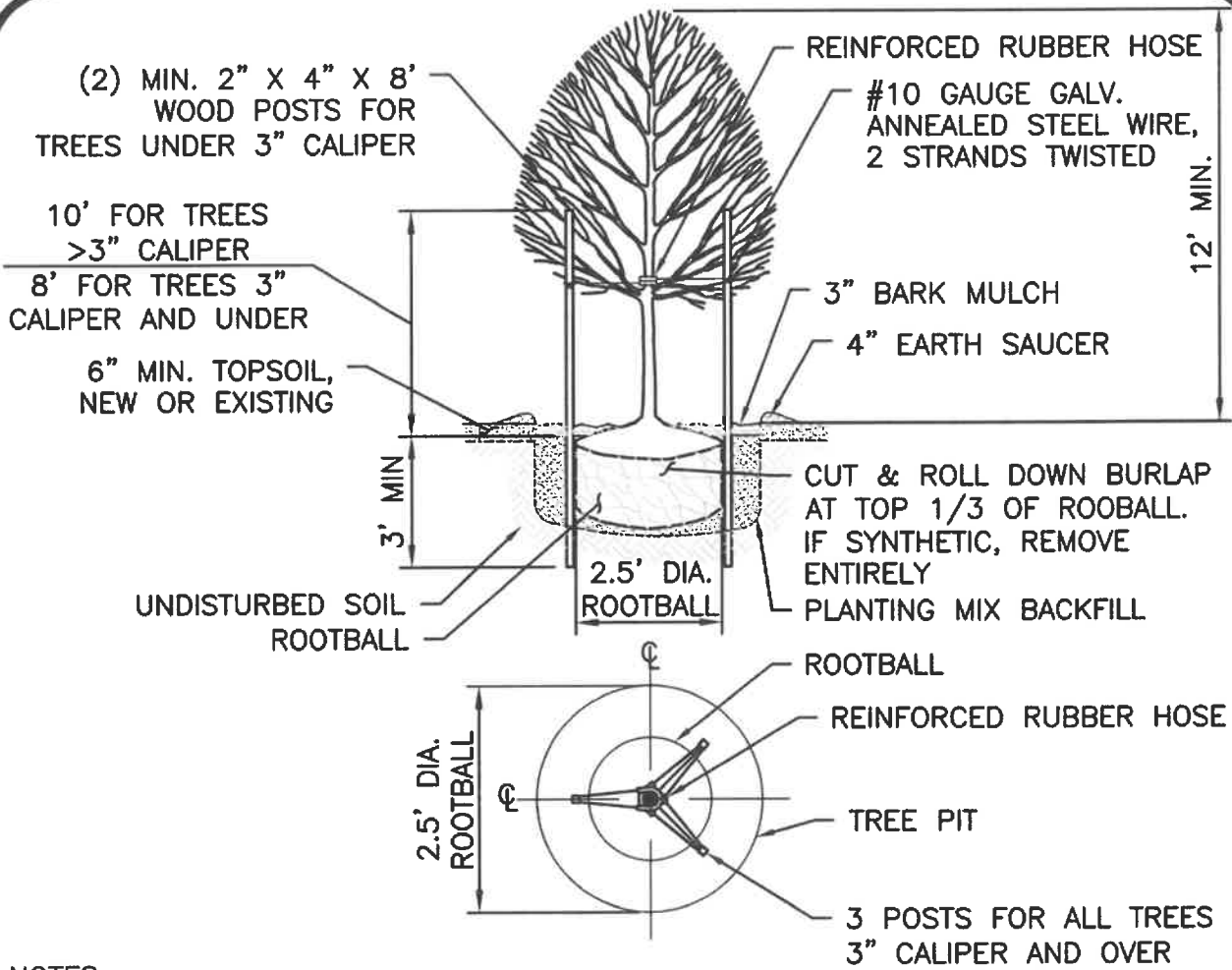

**NOTES:**

1. STREET TREES NOT LESS THAN 12 FEET IN HEIGHT AND OF A SPECIES APPROVED BY THE TREE WARDEN SHALL BE PLANTED ON EACH SIDE OF EVERY STREET IN THE SUBDIVISION WHEREVER, IN THE OPINION OF THE PLANNING BOARD, EXISTING WOODLANDS OR SUITABLE INDIVIDUAL TREES ARE NOT RETAINED.

**STREET TREE DETAIL**  
**NOT TO SCALE**

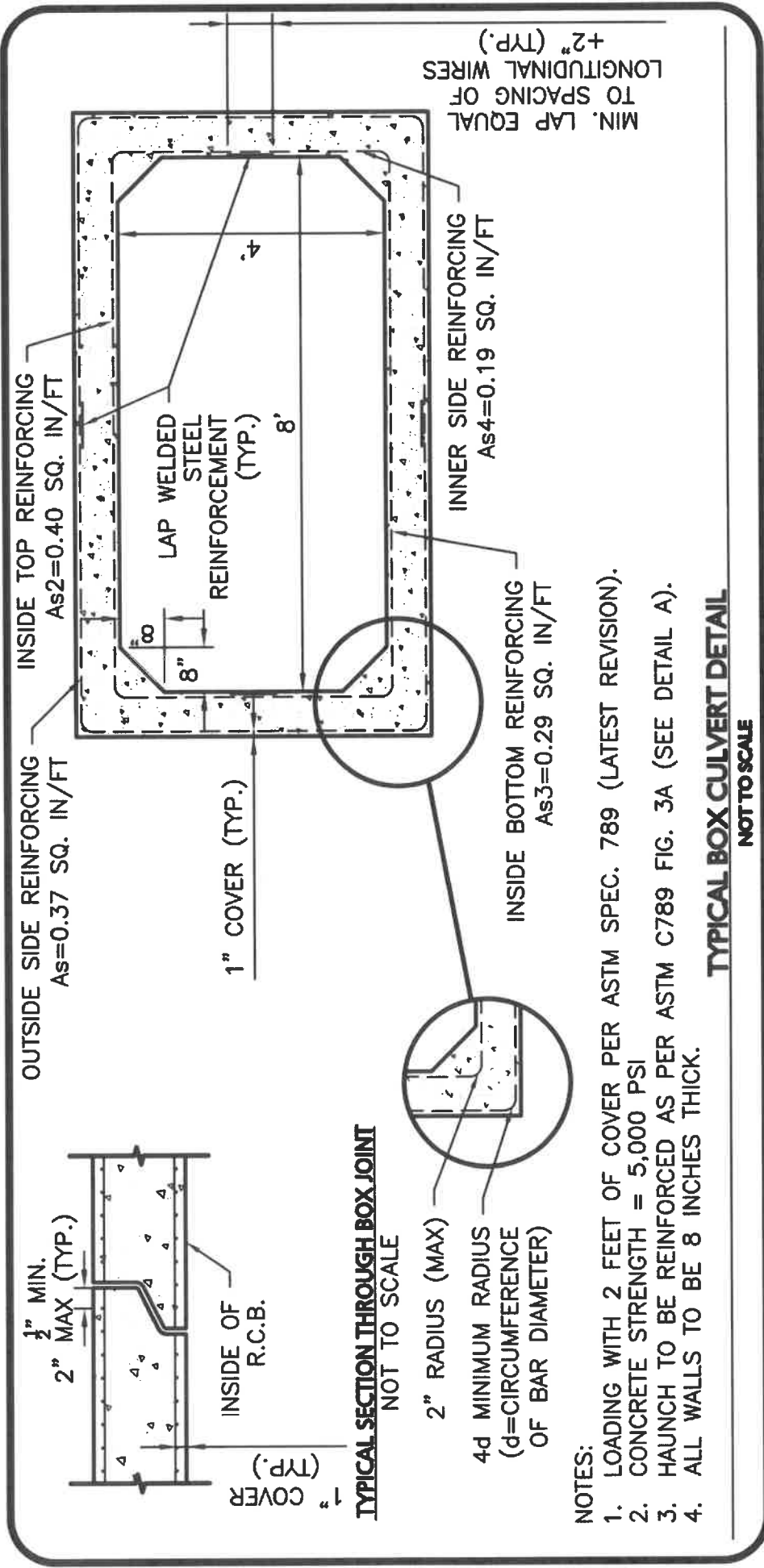

**NOTES:**

1. LOADING WITH 2 FEET OF COVER PER ASTM SPEC. 789 (LATEST REVISION).
2. CONCRETE STRENGTH = 5,000 PSI
3. HAUNCH TO BE REINFORCED AS PER ASTM C789 FIG. 3A (SEE DETAIL A).
4. ALL WALLS TO BE 8 INCHES THICK.

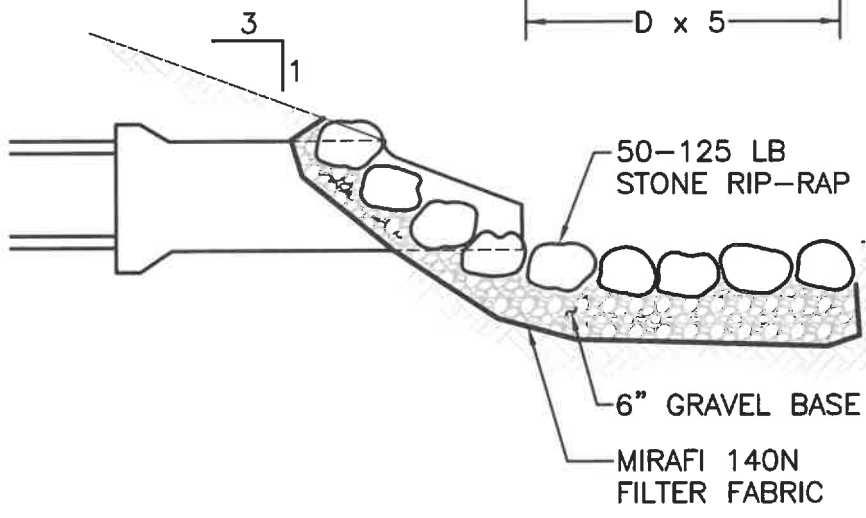
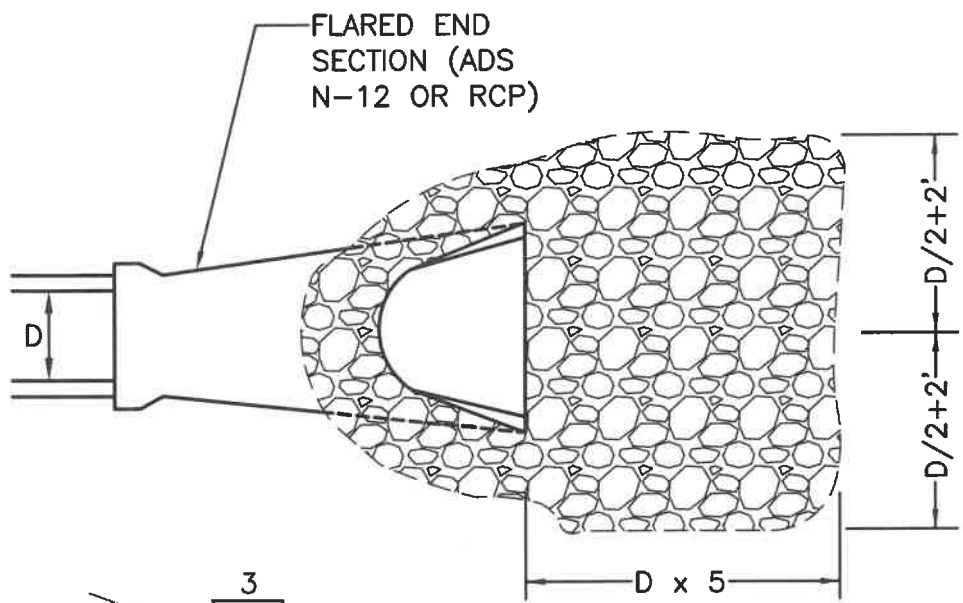

**TYPICAL OUTLET DETAIL**  
 NOT TO SCALE

- RESIDENTIAL MINOR STREET - 40' R.O.W.
- RESIDENTIAL LOCAL STREET - 40' R.O.W.
- RESIDENTIAL STANDARD STREET - 50' R.O.W.
- RESIDENTIAL COLLECTOR STREET - 50' R.O.W.

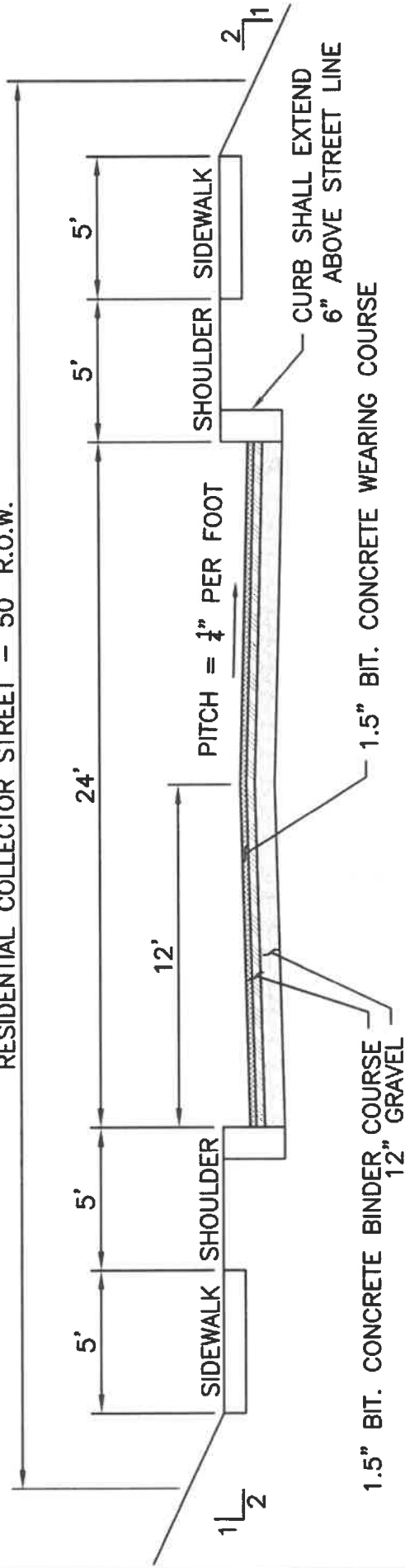

**NOTES:**

1. ALL STREETS SHALL BE DESIGNED AND CONSTRUCTED IN CONFORMANCE WITH THE TOWN OF WAREHAM SUBDIVISION RULES & REGULATIONS.

**TYPICAL RESIDENTIAL STREET WITH SIDEWALKS DETAIL**

NOT TO SCALE



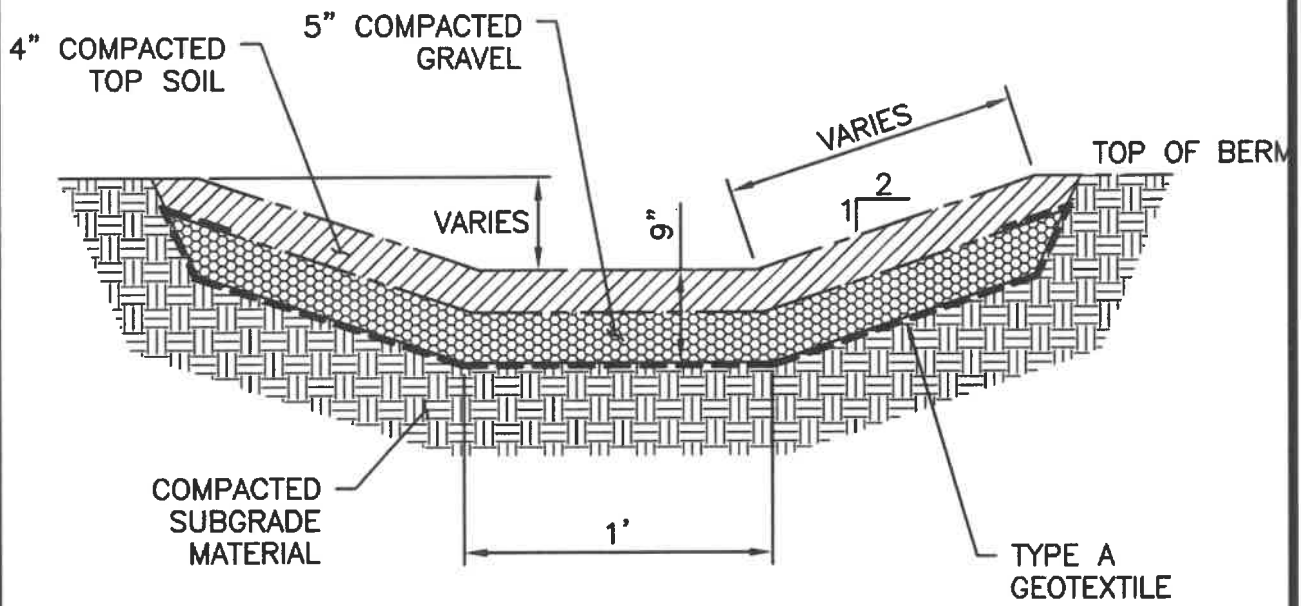

**TYPICAL SWALE DETAIL**  
**NOT TO SCALE**

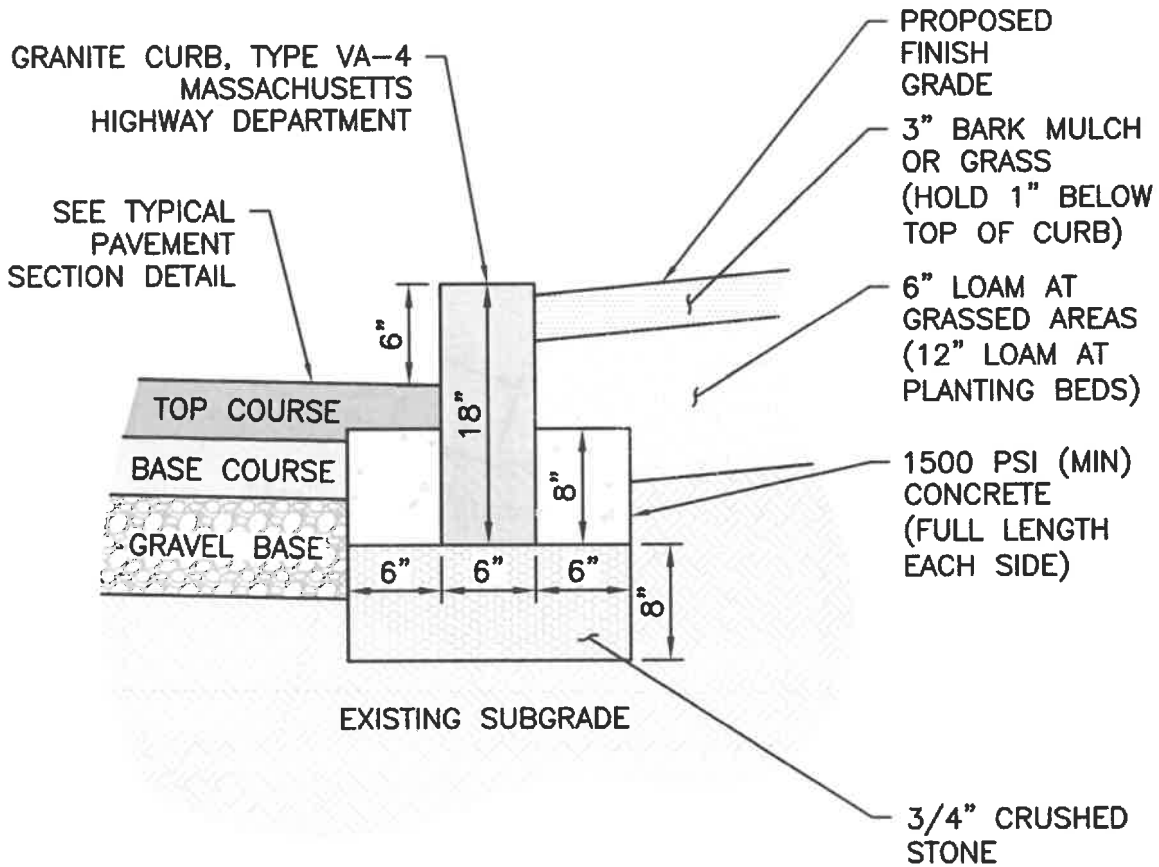

**NOTES:**

1. CURBING SHALL BE CONSTRUCTED ON BOTH SIDES OF THE STREET IN CONFORMANCE WITH THE SPECIFICATIONS OF THE DIRECTOR OF MUNICIPAL MAINTENANCE AND THE TOWN ENGINEER.

**VERTICAL GRANITE CURB DETAIL**

NOT TO SCALE